



# COLLECTIBLE DESIGN

A curated selection of our collectible pieces,  
meticulously crafted to meet rigorous  
standards, seamlessly blending the realms of  
art and design.



THEURBANATIVE

NOT JUST FURNITURE

---

## OUR COLLECTIBLE PIECES

Our collection of collectible pieces represents the epitome of craftsmanship, where each item is thoughtfully curated and meticulously crafted. These pieces are not merely products; they are works of art that embody a harmonious blend of creativity, precision, and timeless design.

## SLOWLY MADE TO UNCOMPROMISING STANDARDS WITH A COLLABORATIVE SPIRIT

In a world driven by rapid production and fleeting trends, we take a deliberate and measured approach to creating our collectibles. Each piece is slowly made, honoring the traditional methods of craftsmanship while integrating modern techniques. This careful and intentional process ensures that every detail, no matter how minute, is executed to perfection. Our commitment to quality means that we adhere to the highest standards at every stage of production, from the selection of materials to the final finishing touches. This meticulous attention to detail guarantees that each piece not only meets but exceeds expectations for durability, beauty, and function. Moreover, our process is deeply collaborative, involving artisans, designers, and craftspeople who bring their unique skills and perspectives to the table, resulting in a richer and more diverse creative outcome.





## BALANCING THE INTERSECTION OF ART AND DESIGN

Our collectibles occupy a unique space where art and design intersect. They are more than functional objects; they are expressions of artistic vision and design excellence. Each piece tells a story, evoking emotion and inspiring admiration. The design is purposeful and intuitive, ensuring usability without compromising on aesthetic value.

### ARTISTIC VISION

**Aesthetic Excellence:** Each piece is designed with a keen eye for detail, ensuring it is visually captivating and artistically significant. The forms, colors, and textures are carefully chosen to create a cohesive and striking visual experience.

**Symbolic Meaning:** Our collectibles often carry deeper meanings or themes, reflecting cultural, historical, or personal narratives. This symbolic richness adds layers of appreciation for those who engage with them.

### DESIGN INTEGRITY

**Functional Beauty:** While our pieces are undeniably beautiful, they are also designed to be practical. This duality ensures that they enhance the aesthetic appeal of a space while serving a functional purpose.

**Innovative Craftsmanship:** We push the boundaries of traditional design by incorporating innovative techniques and materials. This fusion of old and new creates pieces that are both contemporary and timeless.

### THE VALUE OF COLLECTIBILITY

Owning one of our collectible pieces is more than acquiring an object; it is investing in a legacy of art and design. These pieces are created to be cherished and passed down through generations, increasing in value and significance over time. Each collectible is a testament to our dedication to excellence, embodying a rich tradition of craftsmanship and a forward-thinking approach to design.

Our selection of collectible pieces stands as a testament to the delicate balance between art and design. Slowly made to uncompromising standards with a collaborative spirit, these pieces are a celebration of meticulous craftsmanship and innovative vision. They are designed to be not only functional but also deeply meaningful, making them treasures that enrich any collection and elevate any space.





# NENZIMA WOVEN CONSOLE



THEURBANATIVE

NOT JUST FURNITURE

---



## NENZIMA WOVEN CONSOLE

The Nenzima woven console is inspired by the elongated, sculptural, fine coiffure/hairstyle of Queen Nenzima of the Mangbetu tribe in the DRC during the 1920's & forms part of the 2018 African Crowns Collection. The overall lines and forms of the console are inspired by the distinctive look of the elongated heads of most Mangbetu women during that period. Along with the elongated head, the accompanying details of this distinctive hairstyle was an oval or funnel-shaped updo's finished off with an outward halo, originally symbolic of high social status, this was considered exceptionally attractive and powerful this is represented by the steel plate in the front of this distinctive console.

The Nenzima Woven Console is made from powder-coated steel frame with a solid timber top in a natural finish, complimented by the handwoven & crafted telephone wire disc.

**Nenzima**

*noun*

Nen-zi-ma

Designed and released under the collection name **African crowns** the **NENZIMA** Woven Console pays homage to queen Nenzima of the Mangbetu tribe who was the younger sister of the nineteenth-century ruler, Mbunza and the wife of Okondo, she was reported to be the one of the most powerful person in the court in the first decade of the 20th century.

The overall shape, lines and form of the server along with the weaved detail elements are all inspired by the distinctive look of the elongated heads of most Mangbetu women at the time, resulting from the cultural practice of 'Lipombo', which was a status symbol among the Mangbetu ruling classes at the beginning of the century.

Along with the elongated head, the textural quality of the oval or funnel-shaped coiffure is represented by the intricately woven telephone wire disc which takes center stage in the design of the piece.

Queen Nenzima of  
the Mangbetu Belgian  
Congo ©Congo  
Republic®  
1922 H Lang



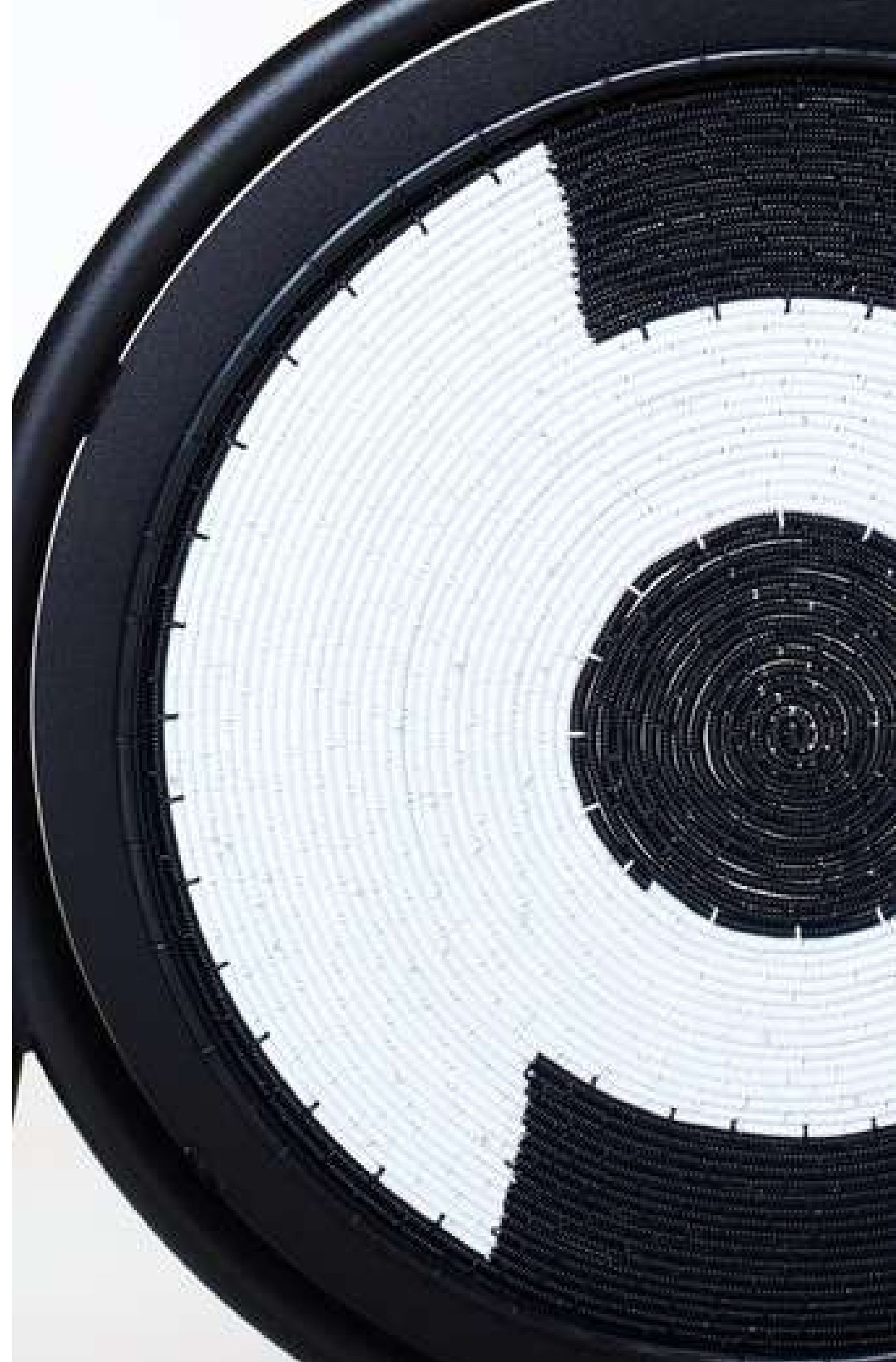



# NENZIMA WOVEN CONSOLE

1500

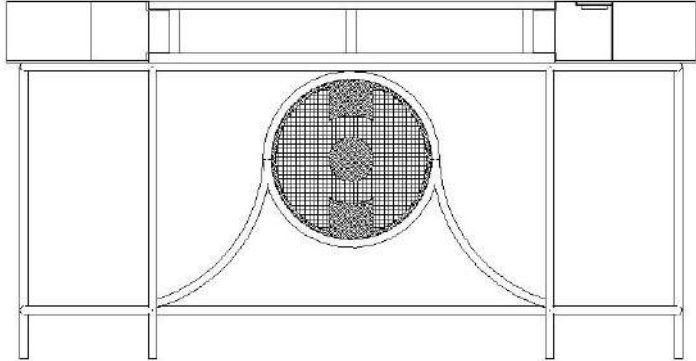

DIMENSIONS 1500 MM X 650 MM X 800 MM

WEIGHT: 30 KG

SKU: DSK04-1500

650

800

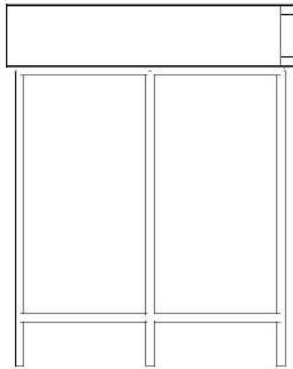

FINISHES: POWDERCOATED STEEL  
BAMBOO TOP  
WOVEN TELEPHONE WIRE

ENQUIRE FOR PRICING

The Nenzima Woven Console is made from powder-coated steel frame with a solid timber top in a natural finish, complimented by the handwoven & crafted telephone wire disc.

ENQUIRE FOR PRICING



**Nenzima**

*noun*

Nen-zi-ma

# NENZIMA WOVEN CONSOLE

## MATERIALS SPEC SHEET

### STANDARD TIMBER



Bamboo ( Side Pressed-Caramel)  
Natural Finish  
20 mm



European Ash  
Natural Finish  
20 mm



European Ash  
Ebony Finish  
20 mm

### STANDARD POWDERCOATED STEEL COLOURS

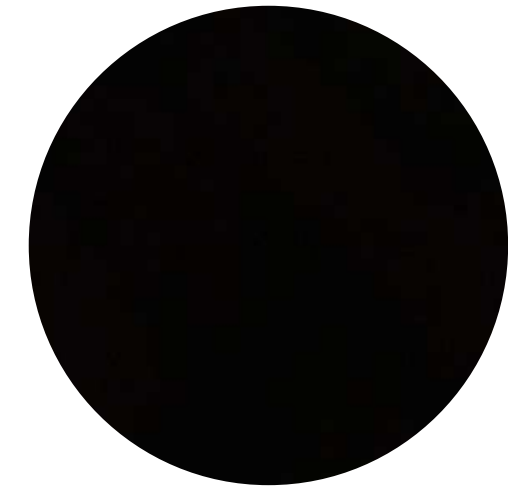

Obsidian (RAL 9011)  
Ferrograin - Indoor

### STANDARD TELEPHONE WIRE COLOURS

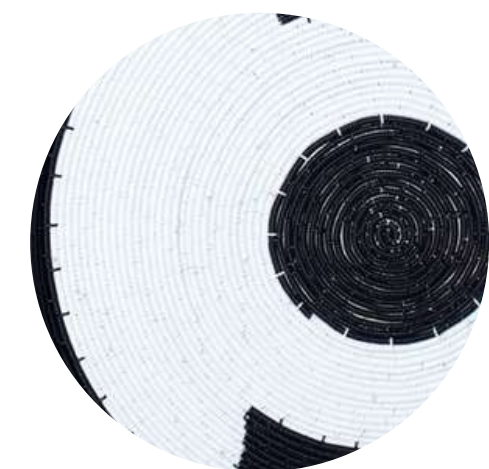

Telephone Wire woven disc

*custom solid timber & powdercoated steel colours available on request.*

Cleaning Instructions available on request.

Timber colours and grain may appear different  
on screen, please request a sample.





# HLUTHA CONSOLE TABLE



THEURBANATIVE  
NOT JUST FURNITURE



## HLUTHA CONSOLE TABLE

The Hlutha console table is part of the Homecoming Collection a 24 piece collection created along with an amazing local community of makers, designers and craft people.. The collection aims to show that the concept of home is not just a physical place but a feeling of warmth, comfort, peace, and a sanctuary for our dreams, hopes and all things we hold dear represented by functional pieces.

Inspired by African vernacular architecture, each piece incorporates form, texture, colour, and patterns, and is named in relation to words that signify home in various African languages.

The Hlutha table means "fullness" in Xhosa, the name inspired by its rounded full powdercoated steel frame drum form finished off in intricately woven details with a solid timber top.

**Hlutha**

*verb*

HL-u-t-ha





## HLUTHA CONSOLE TABLE

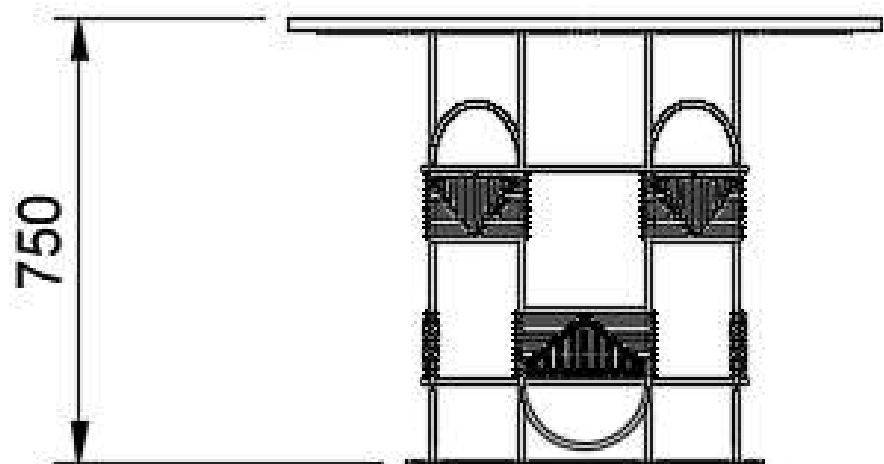

DIMENSIONS 1000 MM X 1000 MM X 750 MM

WEIGHT: 30 KG

SKU: DTB06-1000

FINISHES: POWDERCOATED STEEL  
SOLID WHITE/RED OAK OR ASH TIMBER  
POLYPROP CORD

ENQUIRE FOR PRICING

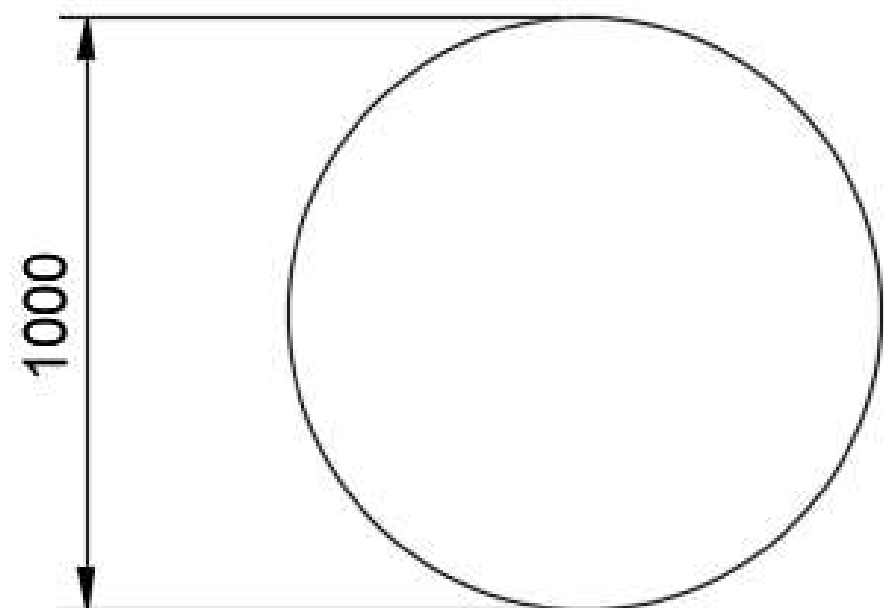

The Hlutha table means "fullness" in Xhosa, the name inspired by its rounded full powdercoated steel frame drum form finished off in intricately woven details with a solid timber top.

ENQUIRE FOR PRICING



**Hlutha**

*verb*

Hl-u-t-ha

**HLUTHA CONSOLE TABLE**  
MATERIALS SPEC SHEET

STANDARD POWDERCOATING COLOURS

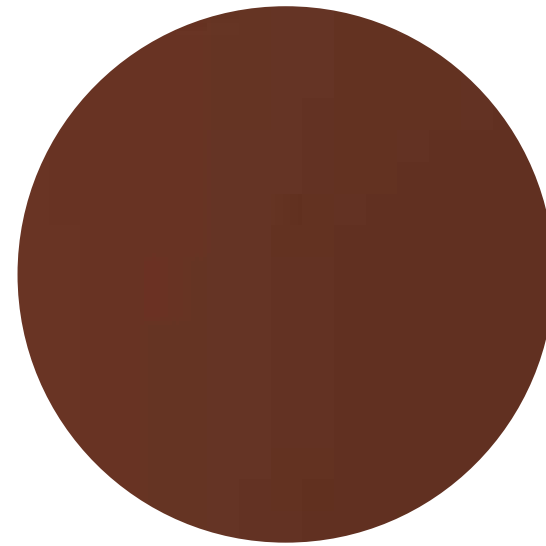

Sienna (RAL 8004)  
Ferrograin - Indoor

Cleaning Instructions available on request.

Please Note: Colours may appear different on screen, please request a sample.

STANDARD CORD COLOURS



CORD: CREAM  
5 mm braided  
polyprop cord



CORD: BEIGE  
5 mm braided  
polyprop cord

*Custom steel & cord colours  
available on request.*



2024

---



# ZORORA QUILT



THEURBANATIVE  
NOT JUST FURNITURE

---



## ZORORA QUILT

The Zorora quilt is a double-sided, handmade masterpiece adorned with wool pom-poms. Aptly named "Zorora," which means "relaxing" in Shona, this quilt embodies tranquility and comfort. Its design draws inspiration from the shapes found in African vernacular architecture, showcasing a unique blend of cultural heritage and modern aesthetics.

Part of the Homecoming Collection, a 24-piece collection created along with an amazing local community of makers, designers, and craftspeople, the Zorora quilt exemplifies the collection's aim to show that the concept of home is not just a physical place but a feeling of warmth, comfort, peace, and a sanctuary for our dreams, hopes, and all things we hold dear, represented by functional pieces. The Zorora quilt not only offers warmth and coziness but also serves as a beautiful piece of art.

**Zorora**

*verb*

Zo-ro-ra



## ZORORA QUILT

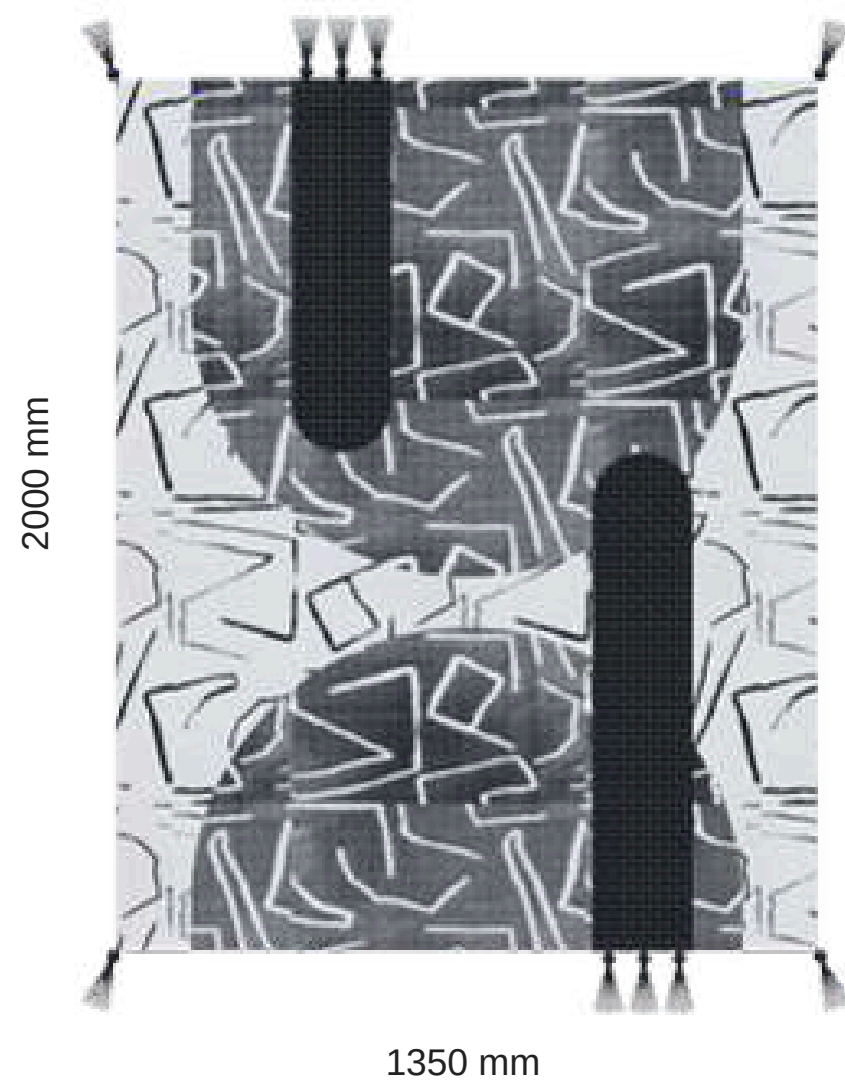

DIMENSIONS 1350MM X 2000MM

WEIGHT: 3 KG

SKU: DTB06-1000

FINISHES: BLENDED FABRICS  
WOOL YARN POM POMS

ENQUIRE FOR PRICING

Aptly named "Zorora," which means "relaxing" in Shona, this quilt embodies tranquility and comfort. Handmade from a blend of fabrics finished off wool pom-poms, the Zorora Quilt not only offers warmth and coziness but also serves as a beautiful piece of art.

Professional cleaning recommended



**Zorora**

*verb*

Zo-ro-ra

# ZORORA QUILT

## MATERIALS SPEC SHEET

### STANDARD FABRIC COLOURS



City Leaves TM14326  
Composition: 100% Polyester  
Width: 145cm  
Repeat: Plain  
Abrasion: >90 000 Martindale Rubs  
Colour Fastness: 5  
Care: Professional Cleaning Recommended



Kelemi Flint TM14617  
Composition: 57% Polyester, 43% Cotton  
Quality: THROW  
Width: 148cm  
Repeat: 37 cm X 47 cm  
Abrasion: 25 000 Martindale Rubs  
Colour Fastness: 6  
Care: Professional Cleaning Recommended  
Finish: Soil & Water Repellent

Cleaning Instructions available on request.

Please Note: Colours may appear different on screen, please request a sample.

*Custom fabrics available on request.*



## MAKGABE OTTOMAN

The Makgabe Ottoman takes inspiration from the traditional Makgabe skirt worn by Setswana girls before they transitioned into womanhood. It symbolized modesty but also cultural identity, reimagining its distinctive woven fringes into a contemporary design object. Like its counterpart, the Wambo Ottoman, the Makgabe Ottoman is fully upholstered with steel feet neatly tucked behind the fringe. Its soft cushioned seat offers comfort and practicality, while the cascading fringe becomes the statement feature.

The fringe references the Makgabe's long, flowing strands of leather, which were historically softened, dyed, and worn around the waist as a symbol of identity and cultural expression by Setswana girls. By amplifying texture through the use of layered fringe, the Makgabe Ottoman not only pays homage to Setswana tradition but also extends the dialogue of the African Crowns Collection—translating heritage, adornment, and storytelling into bold, contemporary furniture.

### **Makgabe**

*noun*

Mah-kgha-beh



All Concepts and Designs are the sole and intellectual property of TheUrbanative PTY (LTD) and should not be reproduced without written consent.

## MAKGABE OTTOMAN

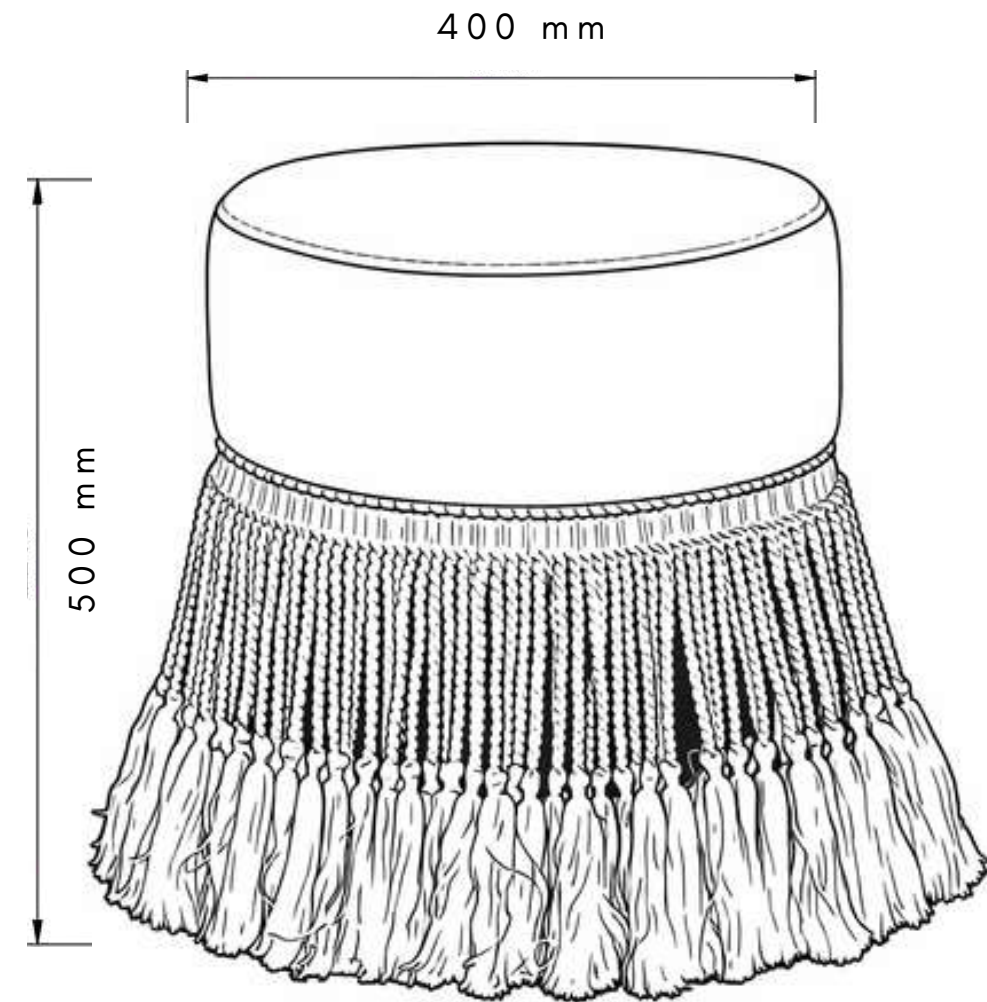

DIMENSIONS 400 MM X 400 MM X 500 MM

WEIGHT: 11,5 KG

SKU: OTT06-500

FINISHES: FABRICS  
COTTON FRINGE

SEAT HEIGHT 450 MM

The Makgabe Ottoman pairs a soft cushioned seat with flowing fringe inspired by the traditional Setswana Makgabe skirt



**Makgabe**

*noun*

Mah-kgha-beh



## WADI PANEL SCREEN

Designed by **TheUrbanative**, the Wadi Screen is a freestanding spatial divider inspired by the Swahili word wadi, meaning valley. Layered hand-woven yarn and sculptural wool reliefs echo the shifting textures and rhythms of natural landscapes, translating material memory into contemporary form.

The screen combines a deliberately fabricated powder-coated steel frame with a hand-woven wool panel and a solid Kiaat wood base. The architectural steel structure provides clarity and rhythm, while the textile introduces softness, depth and visual permeability. The woven panel is produced in collaboration with **Grey Room** using wool supplied by **Weluka**, foregrounding wool as a primary structural and expressive material.

Finished in a red cherry stain, the Kiaat base marks an ongoing material exploration for the studio, extending colour into stained timber to create a cohesive dialogue between wood, metal, and textile.

### WADI

*noun*

Wah-dee



## WADI PANEL SCREEN

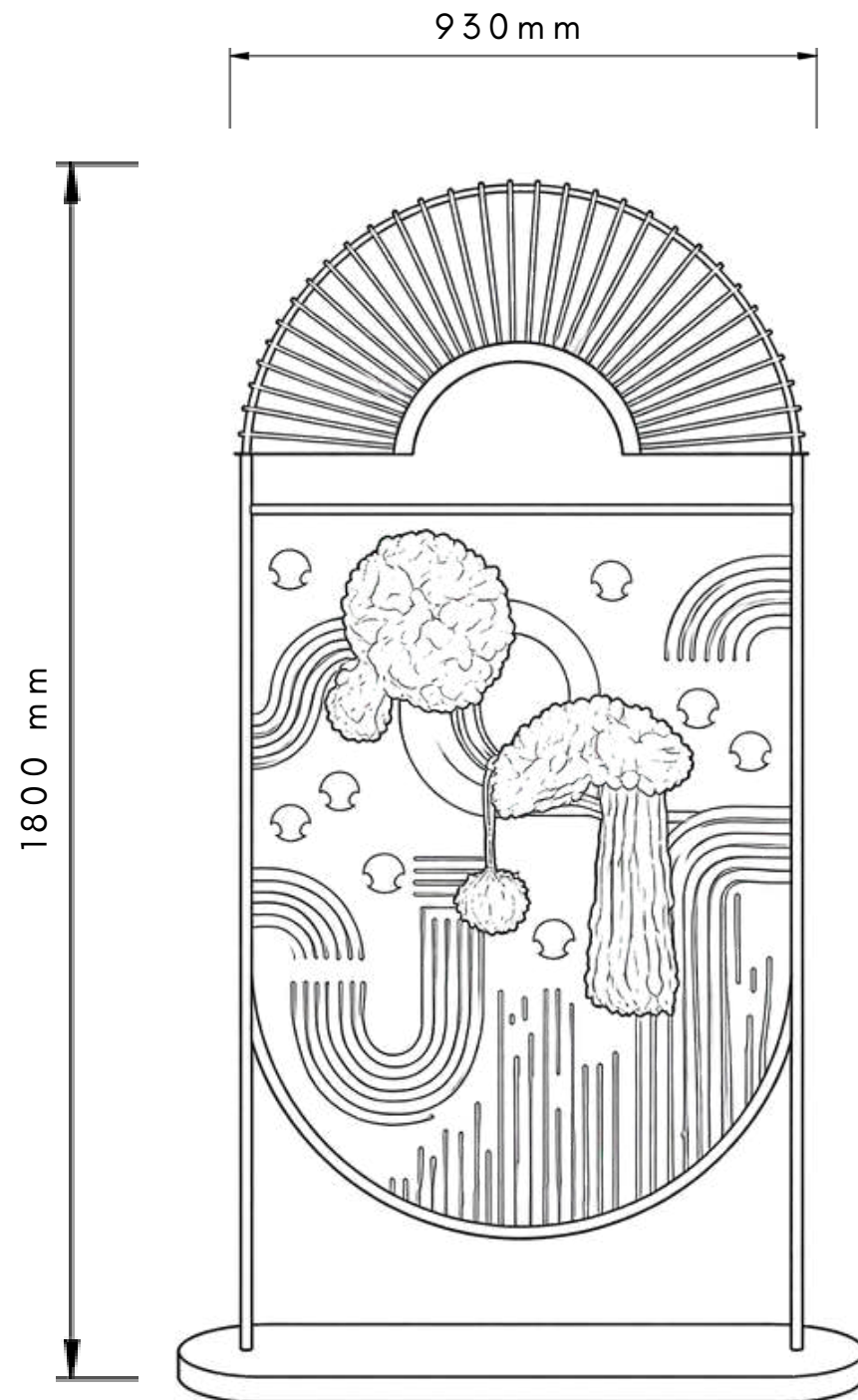

DIMENSIONS 1800 MM X 930MM X 250 MM

WEIGHT: 20 KG

SKU: WADSCR-01

POWDER-COATED STEEL FRAME  
HAND-WOVEN WOOL PANEL  
SOLID KIAAT WOOD BASE  
WOOL YARN AND SCULPTURAL WOOL RELIEF DETAILING

The Wadi Screen is a freestanding spatial divider inspired by the Swahili word wadi, meaning valley. Hand-woven wool textures evoke landscape rhythms and material memory.

A powder-coated steel frame and solid Kiaat base provide structure and balance. Stained timber and textile create a cohesive, contemporary material dialogue.



**WADI**

*noun*

WAH-dee





# FARAJI MIRROR



THEURBANATIVE  
NOT JUST FURNITURE

---



## **FARAJI MIRROR**

IN COLLABORATION WITH Neimil

The Faraji standing mirror is a stunning piece that combines functionality with artistic elegance. Steel framework adorned with tufted wool details and featuring organic shapes, this mirror stands as a testament to meticulous craftsmanship and thoughtful design. The name "Faraji," meaning "consolation" or "comfort" in Swahili, perfectly encapsulates the essence of this piece. It was made in collaboration with Johannesburg based Neimil and offers a sense of solace and warmth to any space it graces.

Part of the Homecoming Collection, a 24-piece collection created along with an amazing local community of makers, designers, and craftspeople, the Faraji standing mirror exemplifies the collection's aim to show that the concept of home is not just a physical place but a feeling of warmth, comfort, peace, and a sanctuary for our dreams, hopes, and all things we hold dear, represented by functional pieces. The Faraji mirror is not only a practical addition to any room but also a beautiful symbol of comfort and home.

### **Faraji**

*noun*

fa-ra-ji



## FARAJI MIRROR

1750 mm

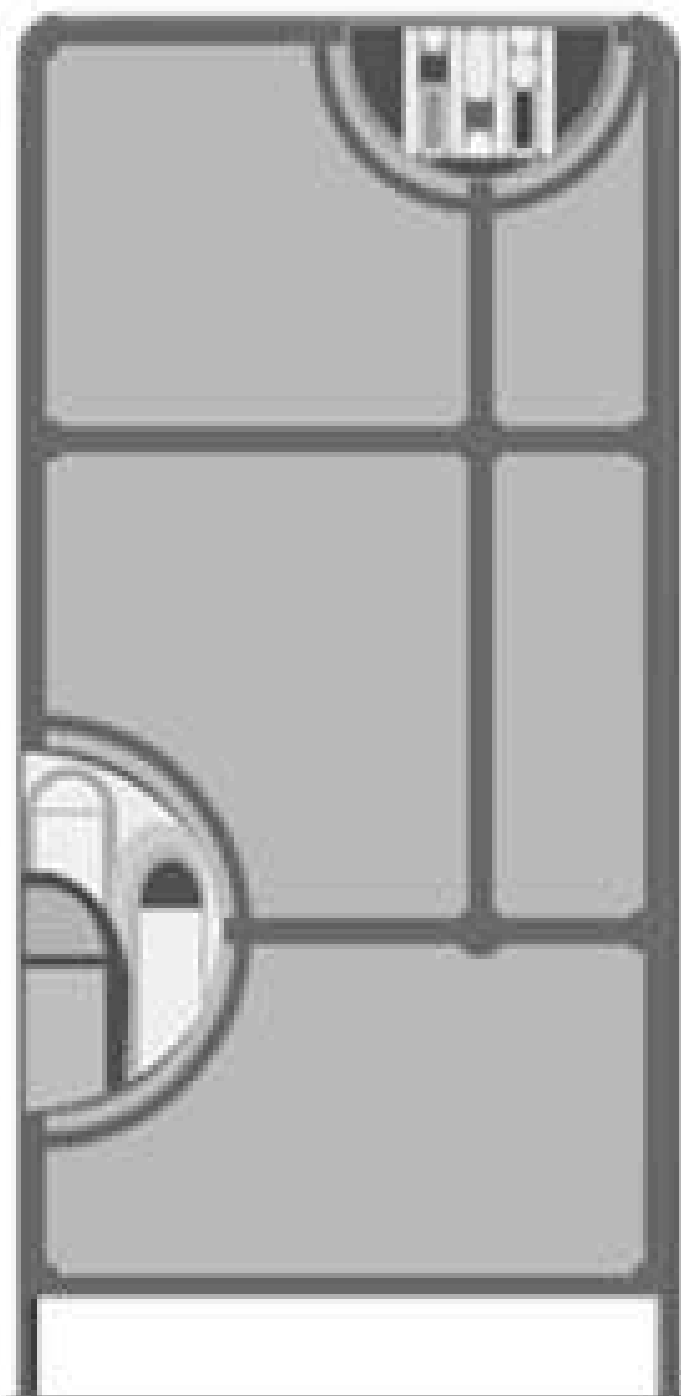

785 mm

DIMENSIONS 785MM X 25MM 1750MM

WEIGHT: 25 KG

SKU: MIR07-1750

FINISHES: POWDERCOATED STEEL  
TUFETED WOOL DETAILS

ENQUIRE FOR PRICING

Steel framework adorned with tufted wool details and featuring organic shapes, this mirror stands as a testament to meticulous craftsmanship and thoughtful design.



**Faraji**

*noun*

fa-ra-ji

**FARAJI MIRROR**  
MATERIALS SPEC SHEET

STANDARD POWDERCOATING COLOURS



Sienna (RAL 8004)  
Ferrograin - Indoor

STANDARD MIRROR FINISHES

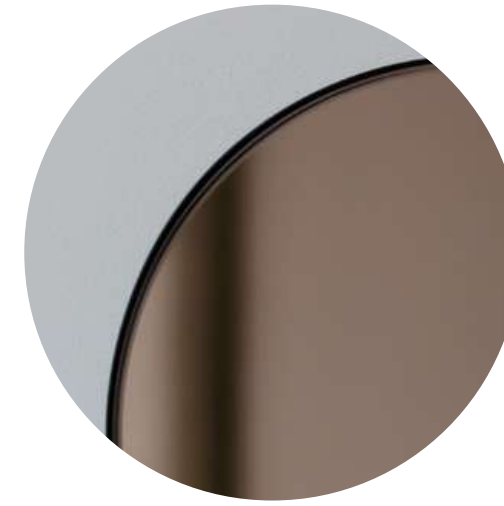

Bronze Tinted Mirror

STANDARD WOOL TUFTED COLOURWAY



WOOL TUFTING

Cleaning Instructions available on request.

Please Note: Colours may appear different on screen, please request a sample.



2024

---

# LUMINOUS MAKEBA

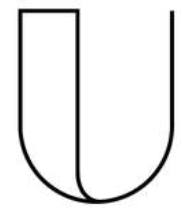

THEURBANATIVE

NOT JUST FURNITURE

---



## LUMINOUS MAKEBA

Named after the legendary South African singer and activist Miriam Makeba, the Luminous Makeba pays tribute to her legacy as a powerful cultural figure and icon of the “Black is Beautiful” movement of the 1960s. Revered for her music and activism, Makeba often celebrated traditional African hairstyles, using her platform to champion African identity and pride.

This collectible sculptural table lamp draws inspiration from the original Makeba Table Lamp and reimagines it in new materiality and form. Crafted from powder-coated steel and a textured stainless steel sheet with a water-like surface, it features cascading stainless steel ball chains that mimic flowing woven locks – evoking both movement and memory.

The Luminous Makeba is more than a lighting piece – it’s a contemporary tribute to heritage, beauty, and resilience, blending symbolism and material storytelling in honour of an African icon.

### **Makeba**

*noun*

Ma-ke-ba





## LUMINOUS MAKEBA TABLE LAMP

500 MM X 500 MM X 1500 MM

WEIGHT: 8 KG

SKU: LUM\_MAK1500

FINISHES: POWDERCOATED STEEL

POLISHED TEXTURED STAINLESS STEEL

BLACK-NICKEL CHROME-PLATED BALL-CHAIN

2000 MM BLACK CORD INCLUDED WITH FOOT SWITCH AND PLUG

LIGHTBULB NOT INCLUDED -  
RECOMMENDED: E27 FITTING / LED 3W /  
4000 K

ENQUIRE FOR PRICING

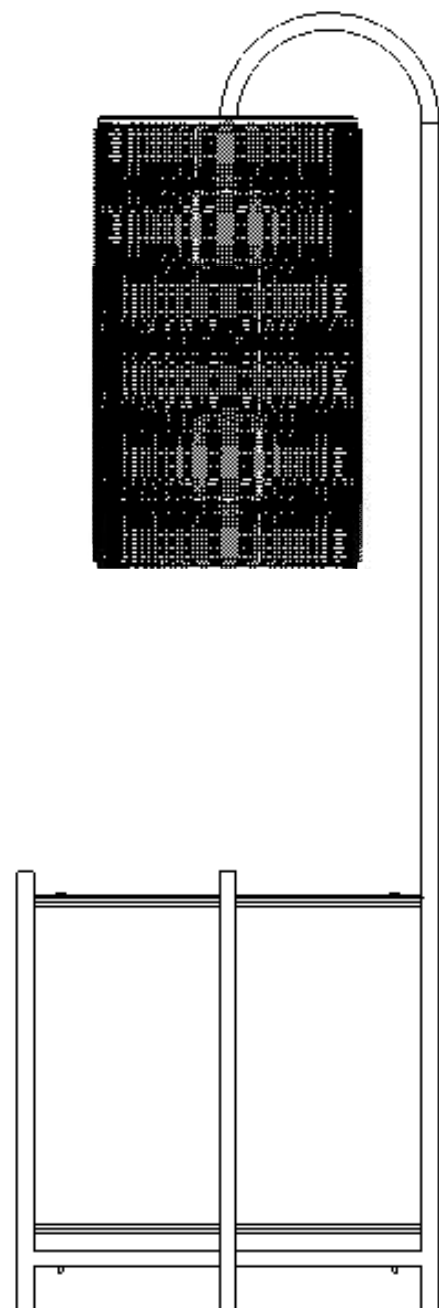

The Luminous Makeba Side-Light-Table is a tribute to material interplay – a dialogue between powder-coated rolled steel tubes, a black-nickel chrome-plated ball-chain veil, textured stainless steel tops, and subtle brass joining details. As part of our 2018 African Crowns Collection, the Luminous Makeba continues the celebration of African hairstyles and the rich cultural narratives they embody, translating heritage into contemporary form.

**Makeba**

*noun*

Ma-ke-ba





# INFINITE FULANI 000



THEURBANATIVE

NOT JUST FURNITURE

---



## INFINITE FULANI 000

The Infinite Fulani was a collaborative piece driven by the idea of future Heirloom, spearheaded by the American Hardwood Export Council supported by Always Welcome, Houtlander and Bos Timbers.

Heirlooms to us are stories that get shared and retold over time; this story can be translated & encapsulated in a physical piece. The Idea of the Infinite Fulani is that of an Heirloom that is constantly evolving, gathering and changing over time as it is passed down from generation to generation, making both the chair and the meaning thereof infinite. An Heirloom pieces that acts a s functional space to collect memories.

The Ombre finish illustrating the passing of time, contemporary enough to fit into a modern space with a deeper meaning of the evolution of the user's journey.

The Infinite Fulani Chair in American red oak is based on the 2018 Fulani chair initially launched and manufactured in steel and we set out to, revisit and add to the original story by exploring new materials and therein new ways of making.

“We aspire to be a brand that not only celebrates stories but one that respects the way in which we tell those stories,” the design and manufacturing approach to everything we do at TheUrbanative is to always be in conversation with the chosen material, the properties and limits thereof; to let the material have a say in the final piece.

This is a one of a kind piece.



# INFINITE FULANI 000

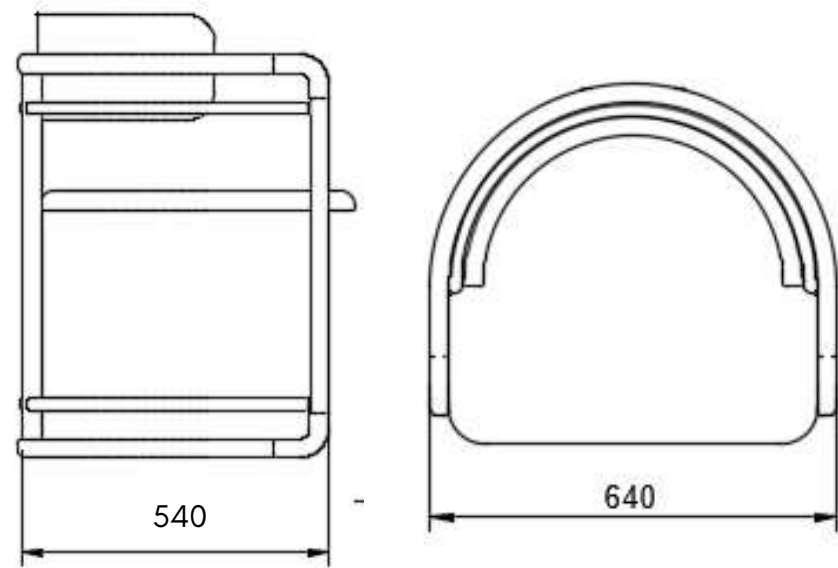
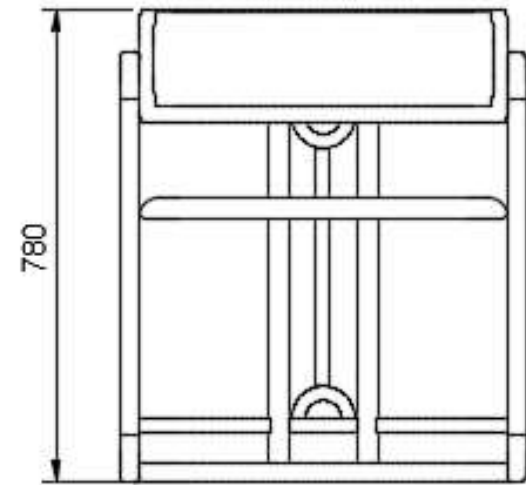

DIMENSIONS 640 MM X 540 MM X 780 MM

---

WEIGHT: 11 KG

---

SKU: INFINFUL-640

---

SEAT HEIGHT 450 MM

---

FINISHES: SOLID RED OAK: CASTLE BROWN FINISH

100% LEATHER BACKREST

HIGH DENSITY MEMORY FOAM

---

ENQUIRE FOR PRICING

The Infinite Fulani 000 is an Heirloom piece, one of a kind has an organic rounded solid red oak timber frame with an upholstered plushly upholstered backrest and solid timber seat to bring chic comfort with a practical touch.

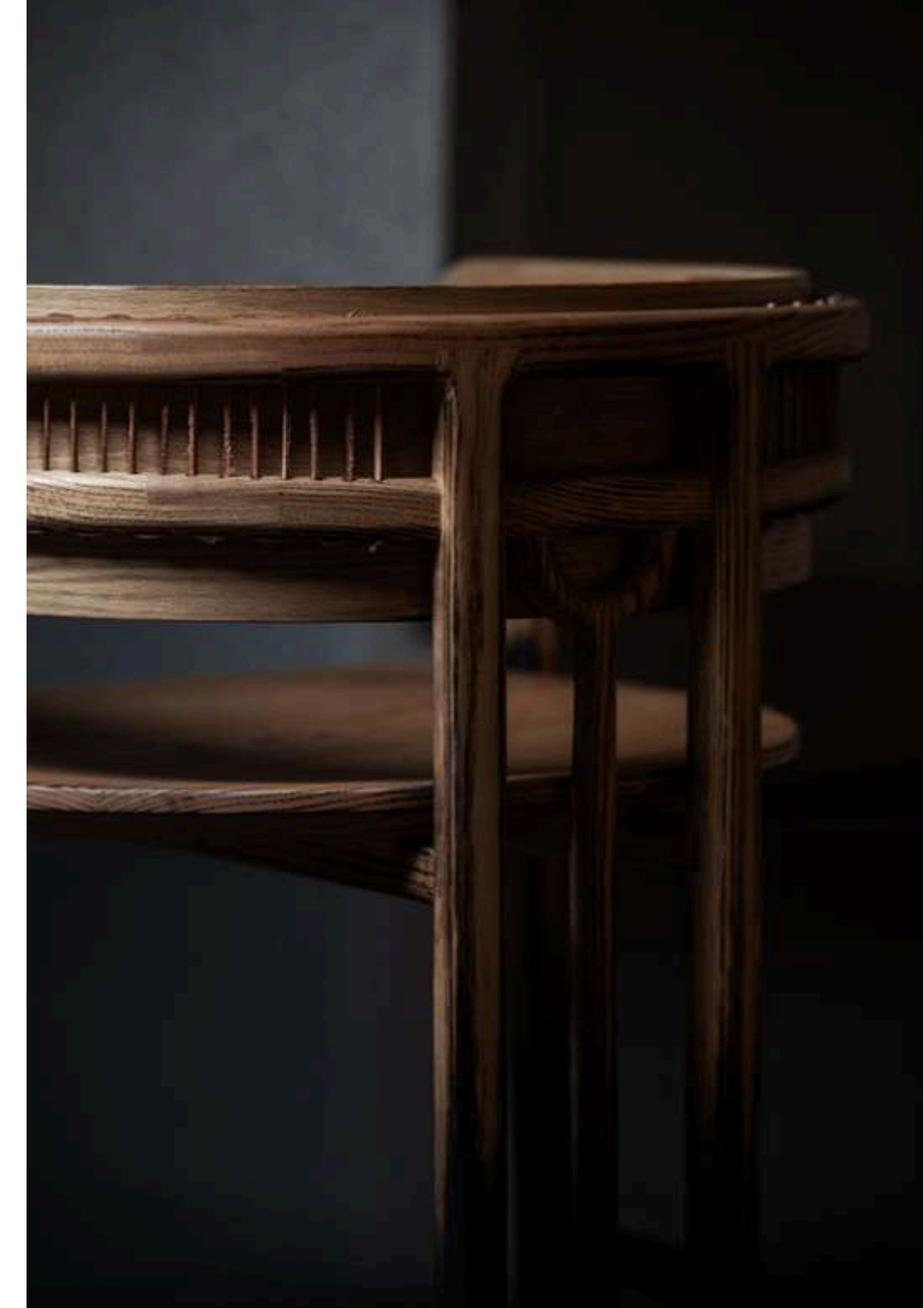

**Fulani**

*noun*

Fu-la-ni

**INFINITE FULANI 000**  
MATERIALS SPEC SHEET

STANDARD TIMBER



Red Oak  
Natural Finish  
20 mm

WOVEN DETAILS



Natural Colour & Finish  
100 % Genuine Leather  
Thonging

BACKREST UPHOLSTERY



100 % Genuine Leather  
PISTA BUTTERSCOTCH

*custom solid timber colours available on request.*

Cleaning Instructions available on request.

Timber colours and grain may appear different  
on screen, please request a sample.





# NASARA CONSOLE



THEURBANATIVE

NOT JUST FURNITURE

---



## NASARA CONSOLE

The Nasara console is named after the Nasara screen and artwork, echoing the sweeping lines and organic shapes, which are abstracted and assembled into a cohesive form.

These curvilinear shapes are originally derived from the first Nasara piece; the Nasara Screen, which then inspired the Nasara abstracted artworks and reclaimed wood vessels. Thereafter these shapes were tessellated into the forms now seen in the console using engineered stone.

This console, features engineered stone inlays on solid Red Oak, a powder-coated steel frame with a 12 mm engineered stone top.

### **Nasara**

*noun*

Na-sa-ra







# NASARA CONSOLE

DIMENSIONS 2050 MM X 550MM X 870MM

WEIGHT: 150 KG

SKU: SER08-2050

FINISHES: POWDERCOATED STEEL  
SOLID RED OAK TIMBER  
PORCELAIN STONEWARE

ENQUIRE FOR PRICING

The Nasara console features a powder-coated steel frame with a 12 mm stone top. It includes red oak solid timber doors, inlaid with 6 mm stone inserts, and a solid red oak shelf inside.

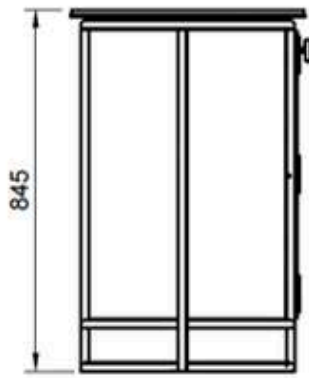
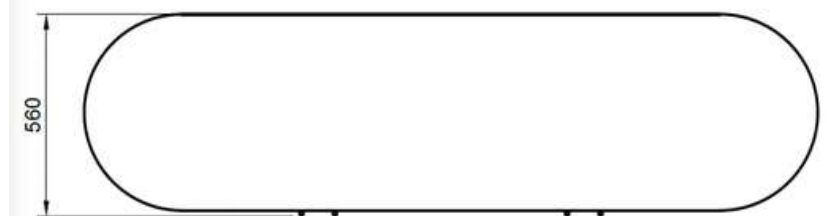
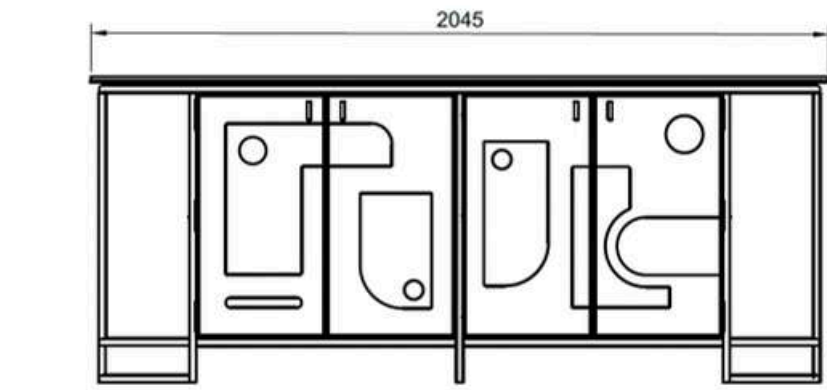

**Nasara**  
*noun*  
Na-sa-ra

# NASARA CONSOLE

## MATERIALS SPEC SHEET

### STANDARD STONEWARE



Calacatta Hermitage  
MB17-SATIN FINISH



Royal Peacock MB20-  
POLISHED

### STANDARD TIMBER



Red Oak  
Natural Finish  
20 mm  
**door inserts & *Interior shelf***

### STANDARD POWDERCOATED STEEL COLOURS

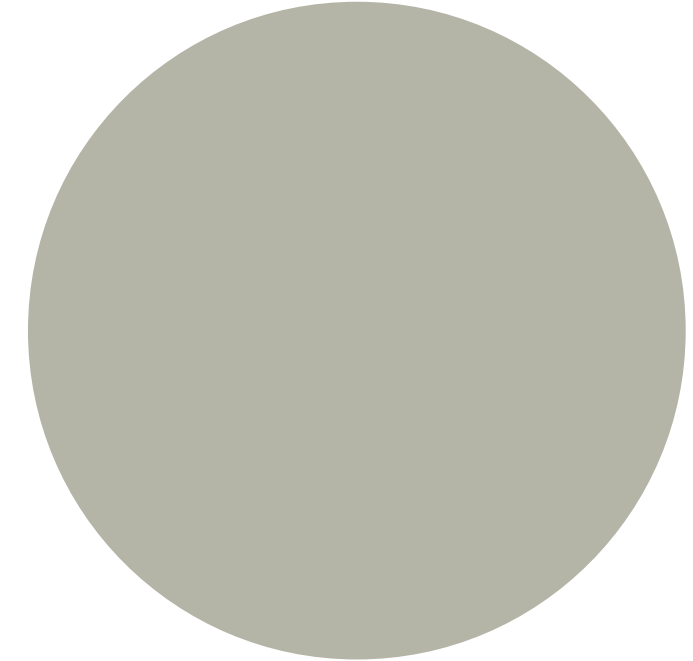

Linen (RAL 7032)  
Ferrograin - Indoor

*custom solid timber & powdercoated steel colours available on request.*

Cleaning Instructions available on request.

Timber colours and grain may appear different  
on screen, please request a sample.





## AYA COLLECTION

At the core of this collection is the influence of **Adinkra symbols**, originating from the **Ashanti** and **Akan** kingdoms of **West Africa**. Each symbol represents related concepts entered around an ideal.

The collection focuses on the **Aya** symbol, pronounced "eye-ah," representing **resourcefulness** and **endurance**. Part of the 700 Adinkra symbols linked to the **Gyaman** kingdom, Aya or "fern" signifies the ability to **overcome adversities**, symbolized by the hardy West African fern.

The collection's materials include **powder-coated recycled steel, reclaimed ostrich egg, and brass elements**—these are intentionally chosen to reflect the symbol's deeper meaning. The **Aya Collection** seeks to honor and promote a deeper understanding of **Adinkra symbology**, ensuring its preservation and appreciation today.

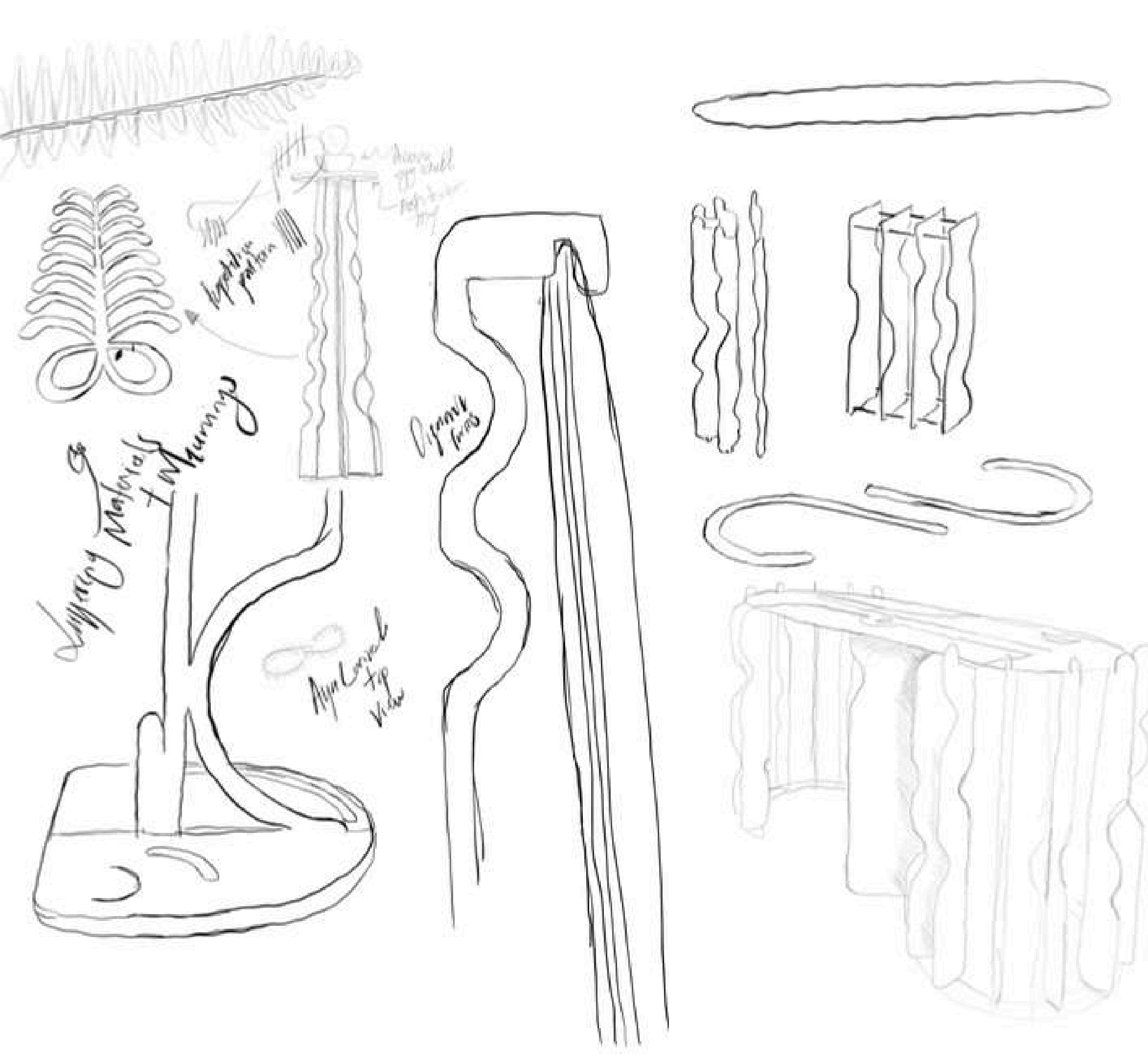

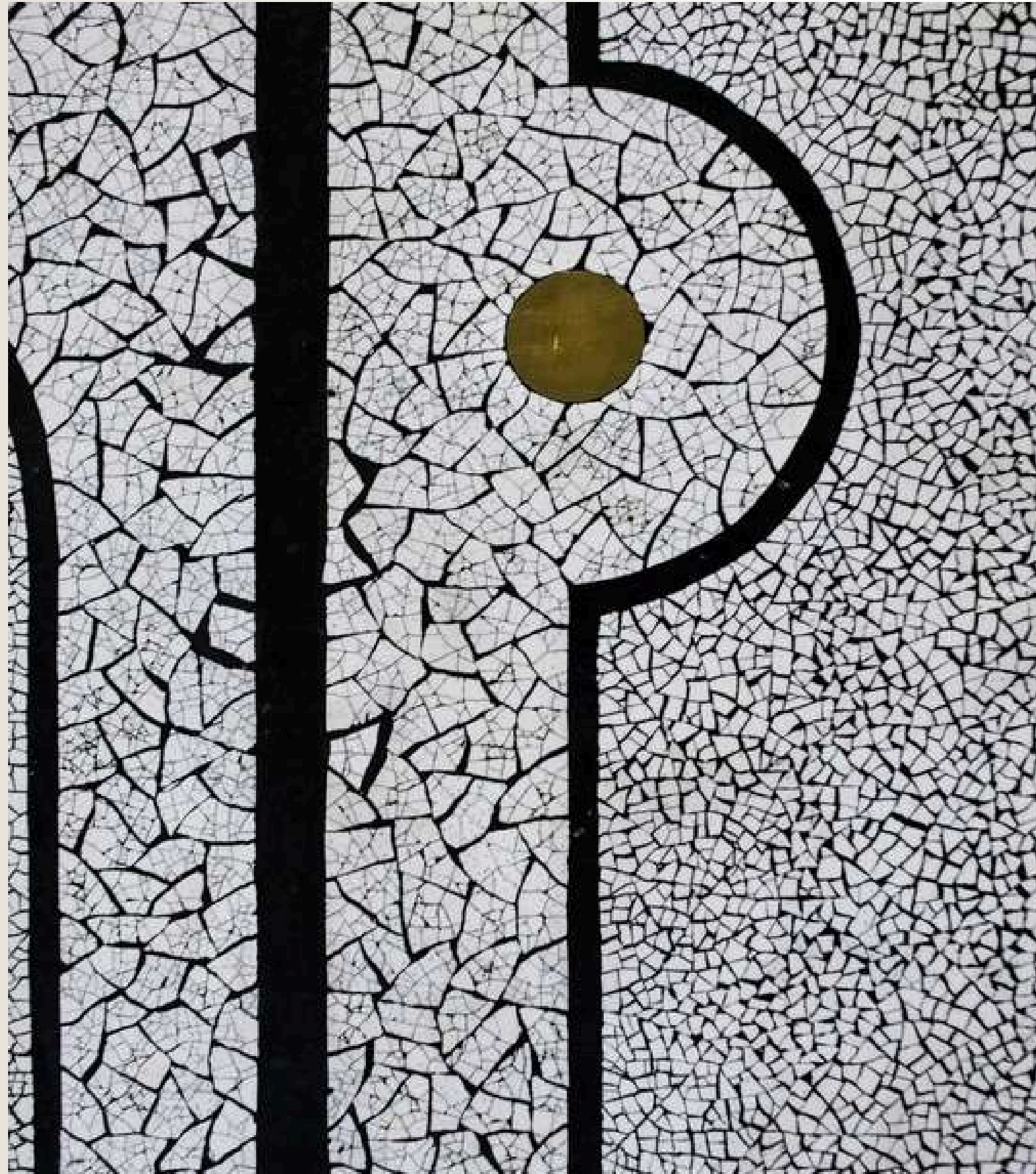

# INFINITE AYA CONSOLE



THEURBANATIVE

NOT JUST FURNITURE

---



**Infinite Aya Console**  
in Collaboration with **AVOOVA**

**Year of creation:** 2024

**Description:**

This console unit features a sturdy framework made of powder-coated mild steel, ensuring durability and a sleek appearance. The surface showcases a mosaic of reclaimed ostrich egg shells embedded in epoxy for a unique, eco-friendly touch. Brass elements enhance both stability and aesthetic appeal.

The Aya or "fern" Adinkra symbol embodies endurance and resourcefulness. It signifies the ability to overcome adversities and endure difficulties, reflecting the hardiness of the West African fern plant. Aya, pronounced as 'eye-ah,' is part of the 700 Adinkra symbols associated with the Gyaman kingdom in Côte d'Ivoire and Ashanti culture in Ghana. The word "Aya" is derived from the Twi language, meaning "fern."

The stylised and simple forms of the pieces that form this collection are inherent of the perceived simplicity of the andrika symbols with a focus on the Aya symbol. However upon further exploration the complexity and layered approach of the design and manufacturing of these pieces is akin to the rich and layered nuances of the Andrika symbols that inspired the collection.

In an effort to explore the message of resourcefulness and endurance of the Aya symbol, the primary materials used for the manufacturing of the collection's pieces are layered in that approach.

This piece has not been fully launched yet and is currently been showcased at the Gallery of Light Showcase by One to One by Martin Doller in Cape Town, South Africa and thereafter is schedule to formally launch at the **Dakar 2024 Biennale in October 2024.**





## INFINITE AYA CONSOLE

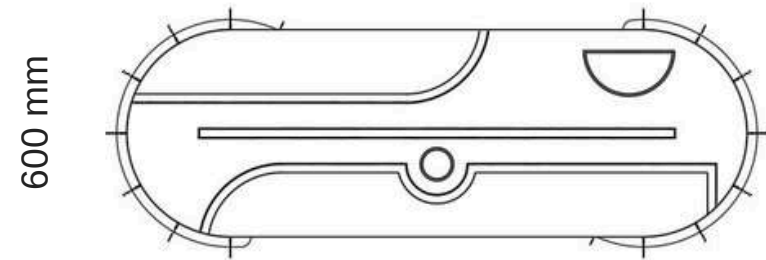
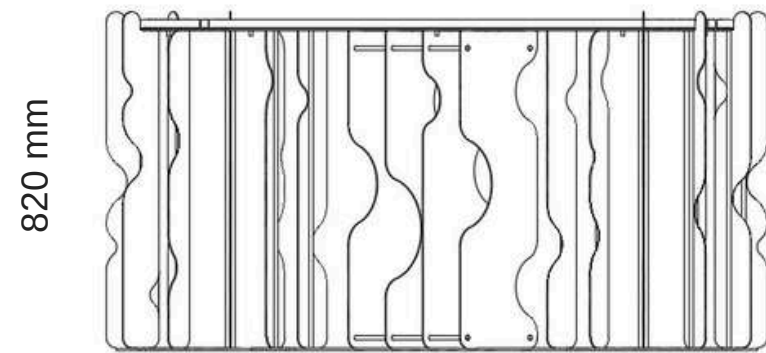

1600 mm

DIMENSIONS 1600 MM X 600 MM X 820 MM

WEIGHT: 110 KG

SKU: AYACON-1600

FINISHES: POWDERCOATED STEEL  
SHARDS OF OSTRICH EGGSHELL  
SOLID BRASS DETAILS

ENQUIRE FOR PRICING

This console unit features a sturdy framework made of powder-coated mild steel, ensuring durability and a sleek appearance. The surface showcases a mosaic of reclaimed ostrich egg shells embedded in epoxy for a unique, eco-friendly touch. Brass elements enhance both stability and aesthetic appeal.



**AYA**

*noun*

A-YA

# INFINITE AYA CONSOLE

## MATERIALS SPEC SHEET

### STANDARD POWDERCOATED STEEL COLOURS

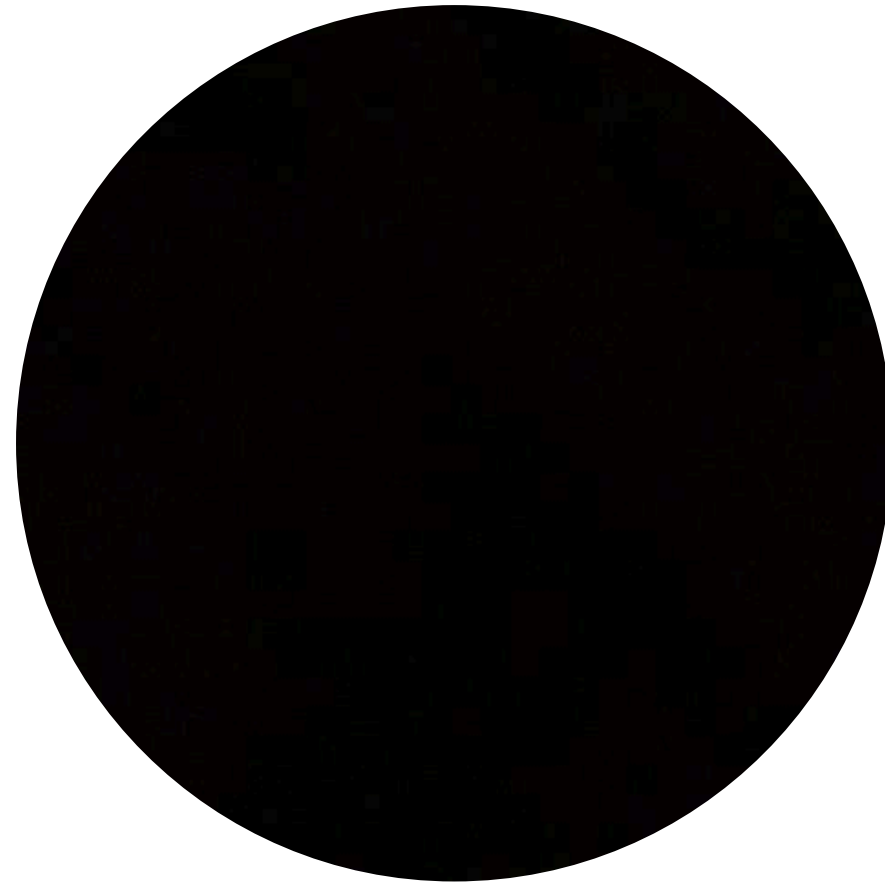

Obsidian (RAL 9011)  
Ferrograin - Indoor

### STANDARD TOP DETAILS

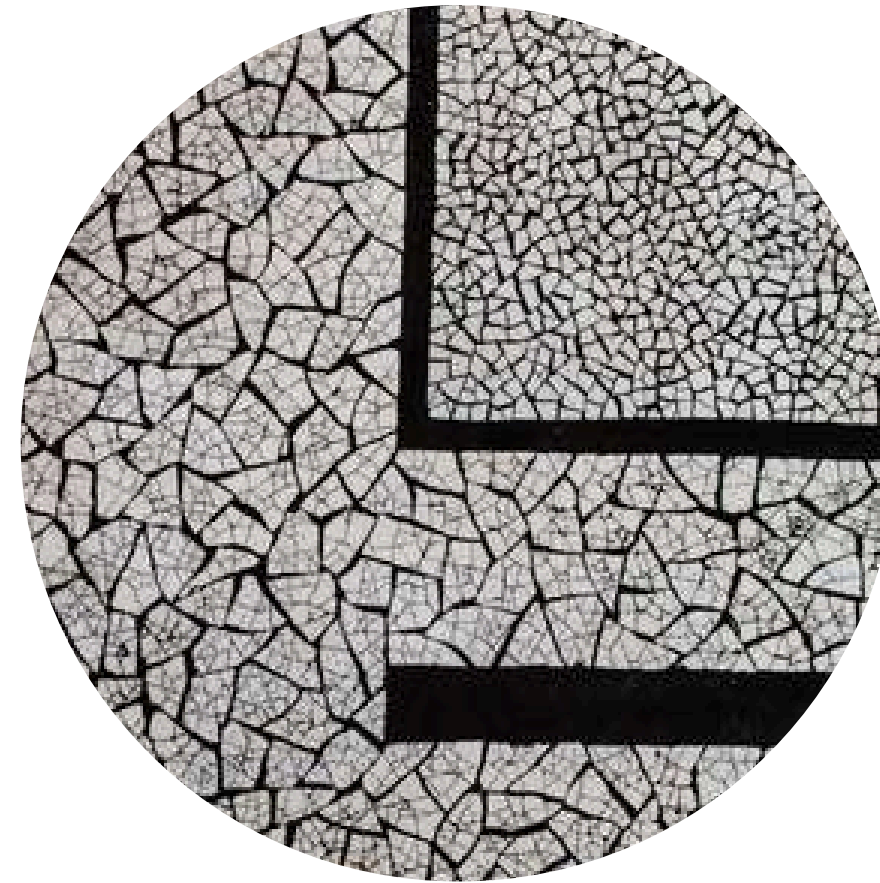

Ostrich Eggshell Mosaic

Cleaning Instructions available on request.

Please Note: Colours may appear different on screen, please request a sample.



# AYA MIRROR



THEURBANATIVE  
NOT JUST FURNITURE

---

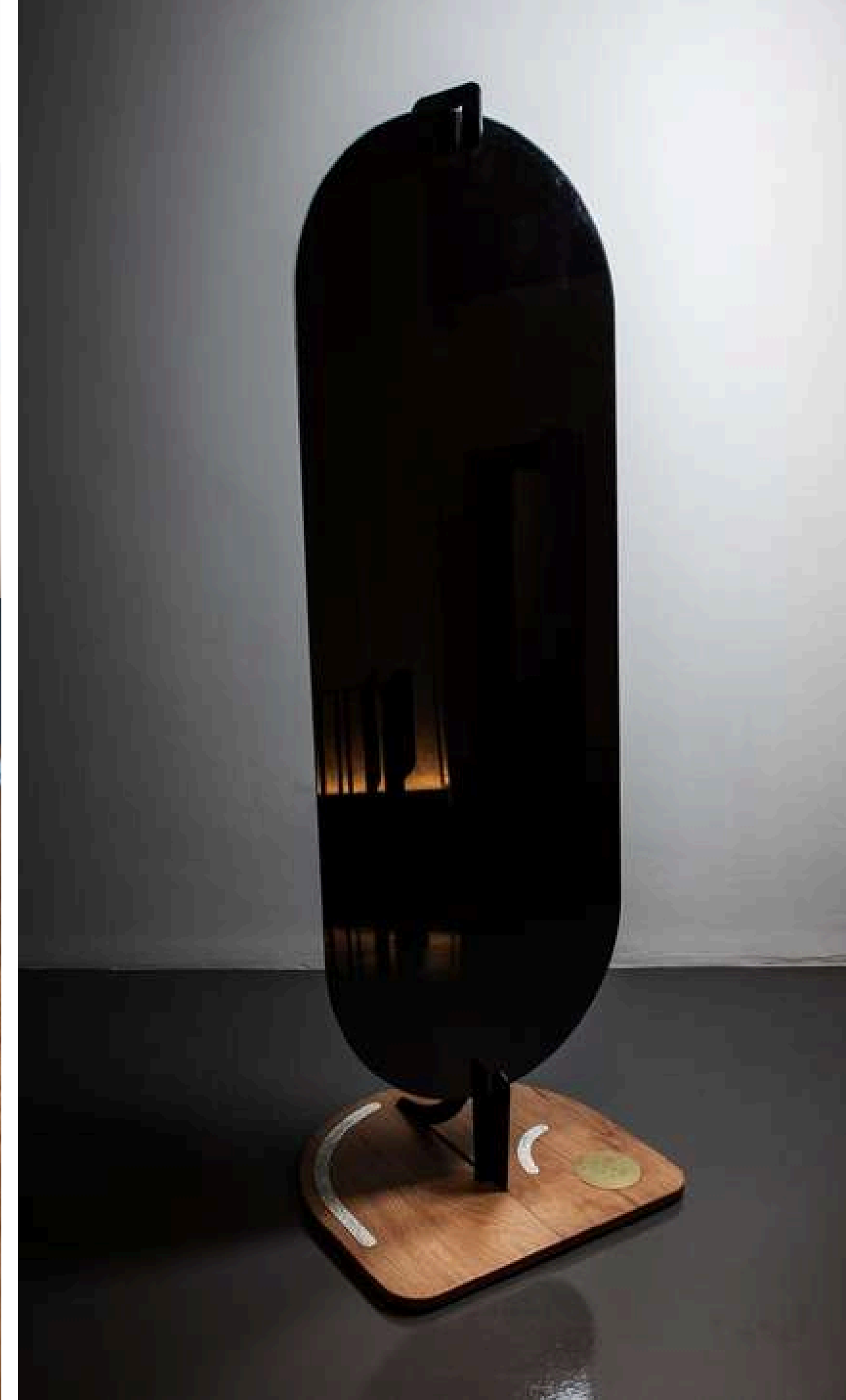

**Aya Mirror**  
in Collaboration with **AVOOVA**

**Year of creation:** 2024

**Description:**

This leaning grey coloured mirror features a sturdy framework made of powder-coated mild steel, solid white oak base with inserts of ostrich eggshell and solid brass details. The details of the mosaic of reclaimed ostrich egg shells is embedded in epoxy for a unique, eco-friendly touch. Brass elements enhance both stability and aesthetic appeal.

The Aya or "fern" Adinkra symbol embodies endurance and resourcefulness. It signifies the ability to overcome adversities and endure difficulties, reflecting the hardiness of the West African fern plant. Aya, pronounced as 'eye-ah,' is part of the 700 Adinkra symbols associated with the Gyaman kingdom in Côte d'Ivoire and Ashanti culture in Ghana. The word "Aya" is derived from the Twi language, meaning "fern."

The stylised and simple forms of the pieces that form this collection are inherent of the perceived simplicity of the andrika symbols with a focus on the Aya symbol. However upon further exploration the complexity and layered approach of the design and manufacturing of these pieces is akin to the rich and layered nuances of the Andrika symbols that inspired the collection.

In an effort to explore the message of resourcefulness and endurance of the Aya symbol, the primary materials used for the manufacturing of the collection's pieces are layered in that approach.

This piece has not been fully launched yet and is currently been showcased at the Gallery of Light Showcase by One to One by Martin Doller in Cape Town, South Africa and thereafter is schedule to formally launch at the **Dakar 2024 Biennale in October 2024.**



# AYA MIRROR

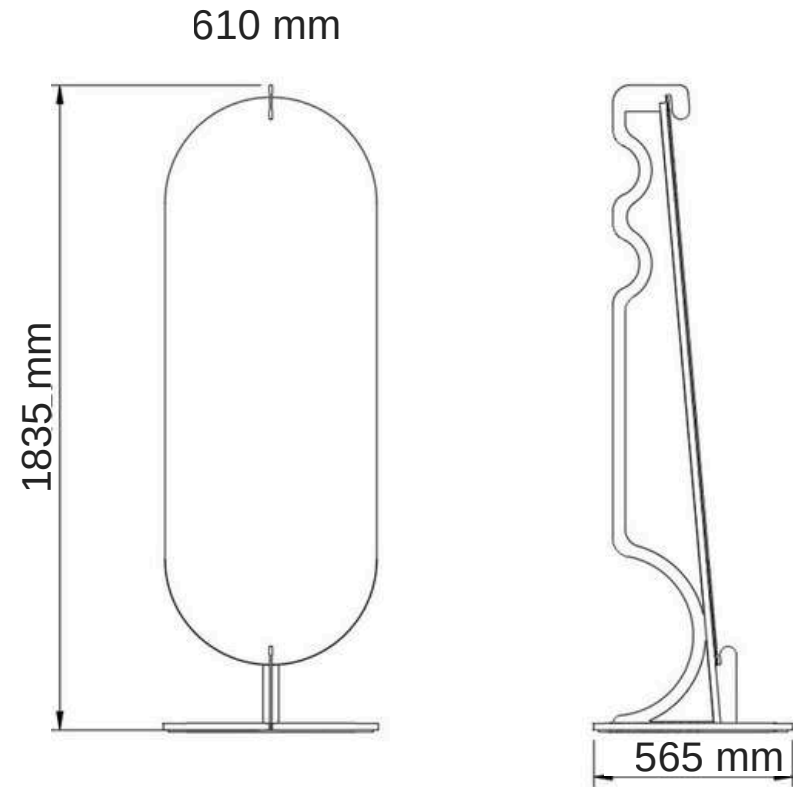

DIMENSIONS 610 MM X 565 MM X 1835 MM

WEIGHT: 80 KG

SKU: AYAMIR-1835

FINISHES: POWDERCOATED STEEL  
SHARDS OF OSTRICH EGGSHELL  
SOLID WHITE OAK  
SOLID BRASS DETAILS  
6 MM GREY COLOURED MIRROR

ENQUIRE FOR PRICING

This leaning grey coloured mirror features a sturdy framework made of powder-coated mild steel, solid white oak base with inserts of ostrich eggshell and solid brass details. The details of the mosaic of reclaimed ostrich egg shells is embedded in epoxy for a unique, eco-friendly touch.

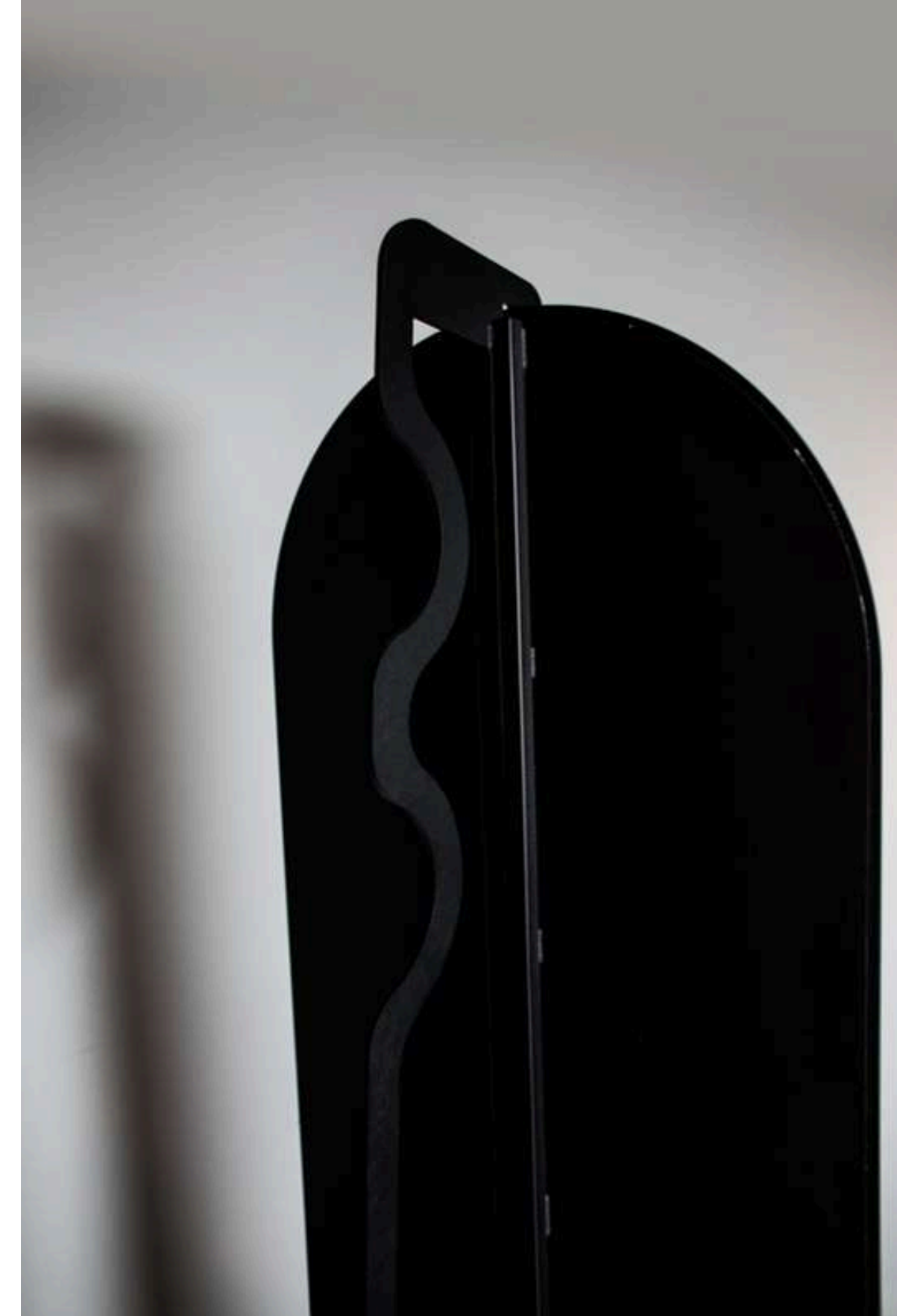

**AYA**

*noun*

A-YA

# AYA MIRROR

## MATERIALS SPEC SHEET

### STANDARD POWDERCOATED STEEL COLOURS

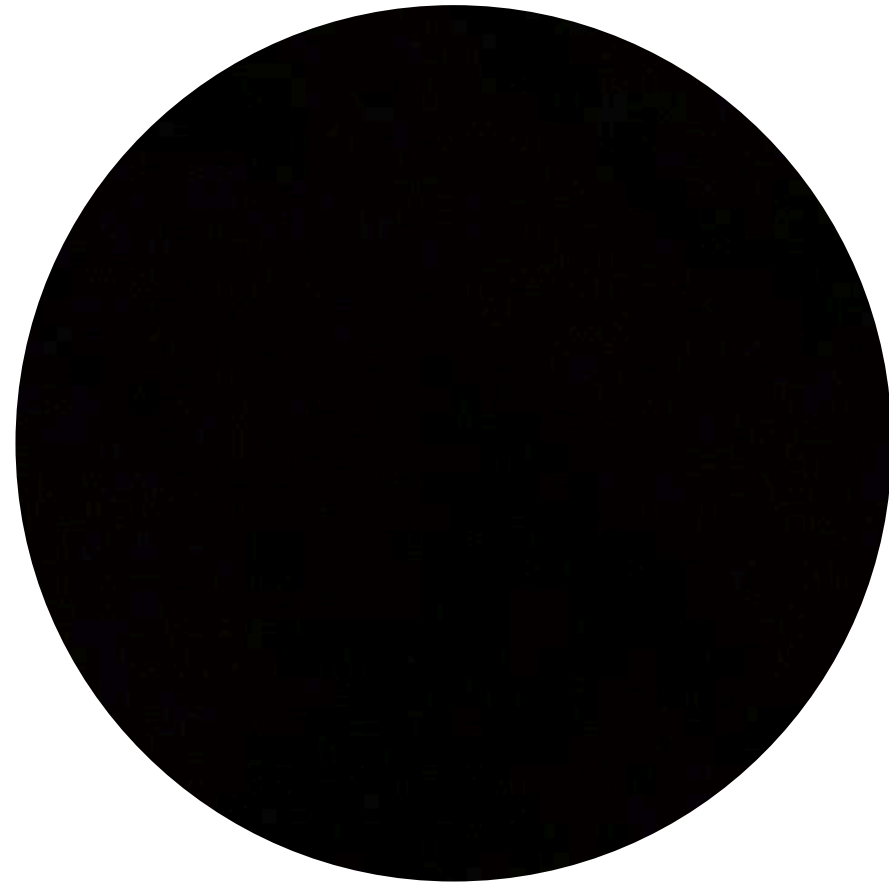

Obsidian (RAL 9011)  
Ferrograin - Indoor

### STANDARD TOP DETAILS

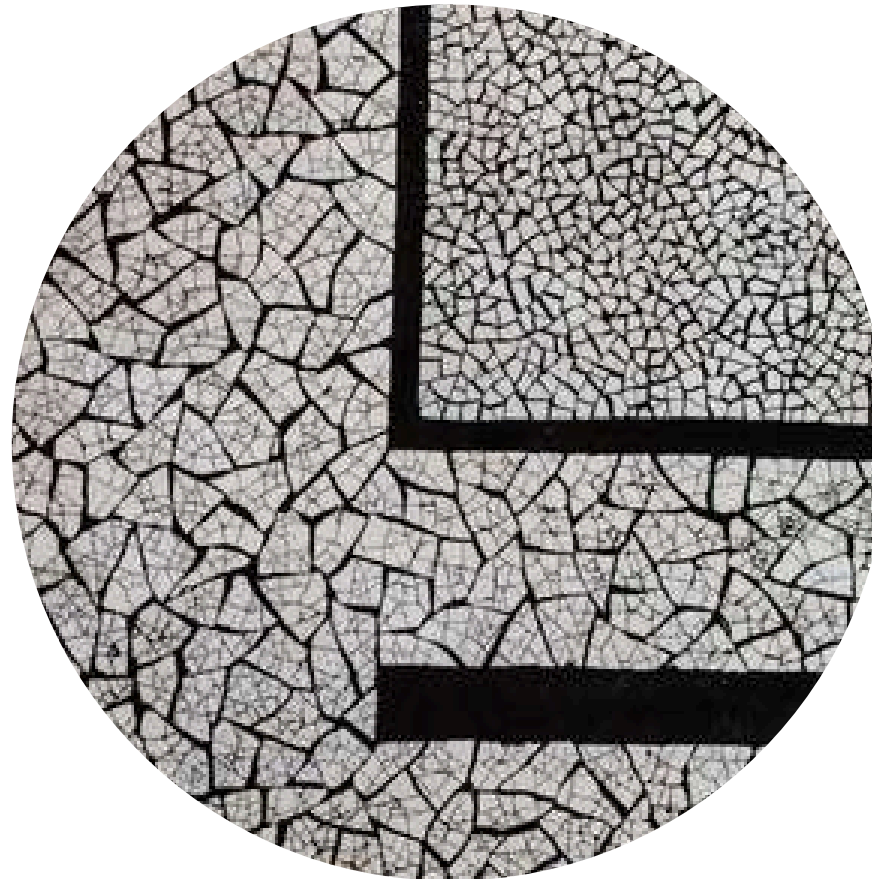

Ostrich Eggshell Mosaic

### STANDARD TOP DETAILS



Solid White Oak

Cleaning Instructions available on request.

Please Note: Colours may appear different on screen, please request a sample.



# AYA OBELISK



THEURBANATIVE

NOT JUST FURNITURE

---



**Aya OBELISK**  
in Collaboration with **AVOOVA**

**Year of creation:** 2024

**Description:**

This contemporary floor lamp boasts a modern design with a powder-coated mild steel frame featuring laser-cut plates. The lampshade showcases a unique mosaic crafted from reclaimed ostrich egg shells in epoxy, supported by a solid oak base and enhanced with brass elements.

The Aya or "fern" Adinkra symbol embodies endurance and resourcefulness. It signifies the ability to overcome adversities and endure difficulties, reflecting the hardiness of the West African fern plant. Aya, pronounced as 'eye-ah,' is part of the 700 Adinkra symbols associated with the Gyaman kingdom in Côte d'Ivoire and Ashanti culture in Ghana. The word "Aya" is derived from the Twi language, meaning "fern."

The stylised and simple forms of the pieces that form this collection are inherent of the perceived simplicity of the andrika symbols with a focus on the Aya symbol. However upon further exploration the complexity and layered approach of the design and manufacturing of these pieces is akin to the rich and layered nuances of the Andrika symbols that inspired the collection.

In an effort to explore the message of resourcefulness and endurance of the Aya symbol, the primary materials used for the manufacturing of the collection's pieces are layered in that approach.

This piece has not been fully launched yet and is currently been showcased at the Gallery of Light Showcase by One to One by Martin Doller in Cape Town, South Africa and thereafter is schedule to formally launch at the Dakar 2024 Biennale in October 2024.



## AYA OBELISK

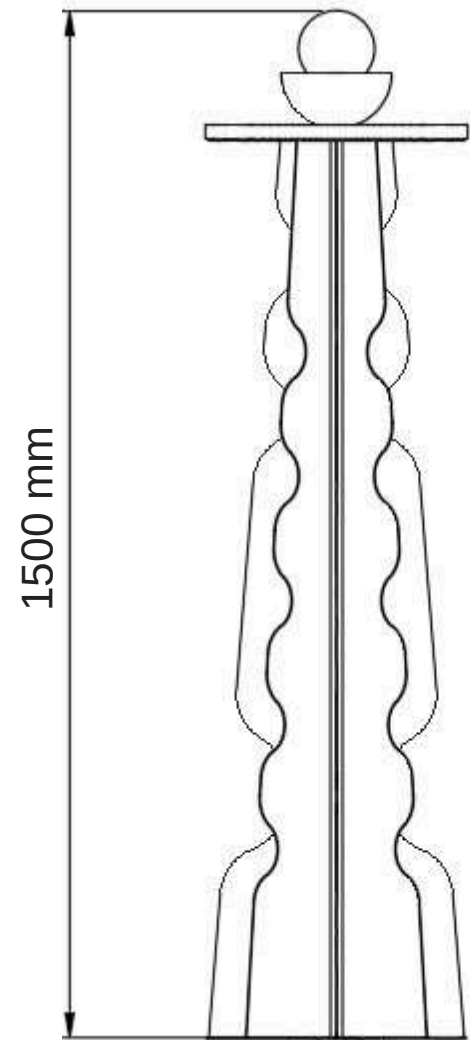
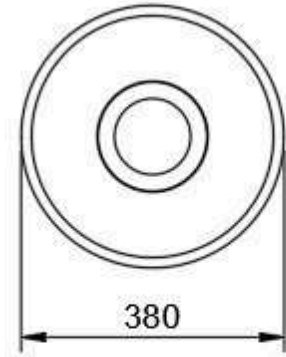

380 mm

DIMENSIONS 380 MM X 380 MM X 1500 MM

WEIGHT: 45 KG

SKU: AYA OBL-1500

FINISHES: POWDERCOATED STEEL  
SHARDS OF OSTRICH EGGSHELL  
SOLID WHITE OAK  
SOLID BRASS DETAILS

ENQUIRE FOR PRICING

This contemporary floor lamp boasts a modern design with a powder-coated mild steel frame featuring laser-cut plates. The lampshade showcases a unique mosaic crafted from reclaimed ostrich egg shells in epoxy, supported by a solid oak base and enhanced with brass elements.



**AYA**

*noun*

A-YA

# AYA OBELISK

## MATERIALS SPEC SHEET

### STANDARD POWDERCOATED STEEL COLOURS

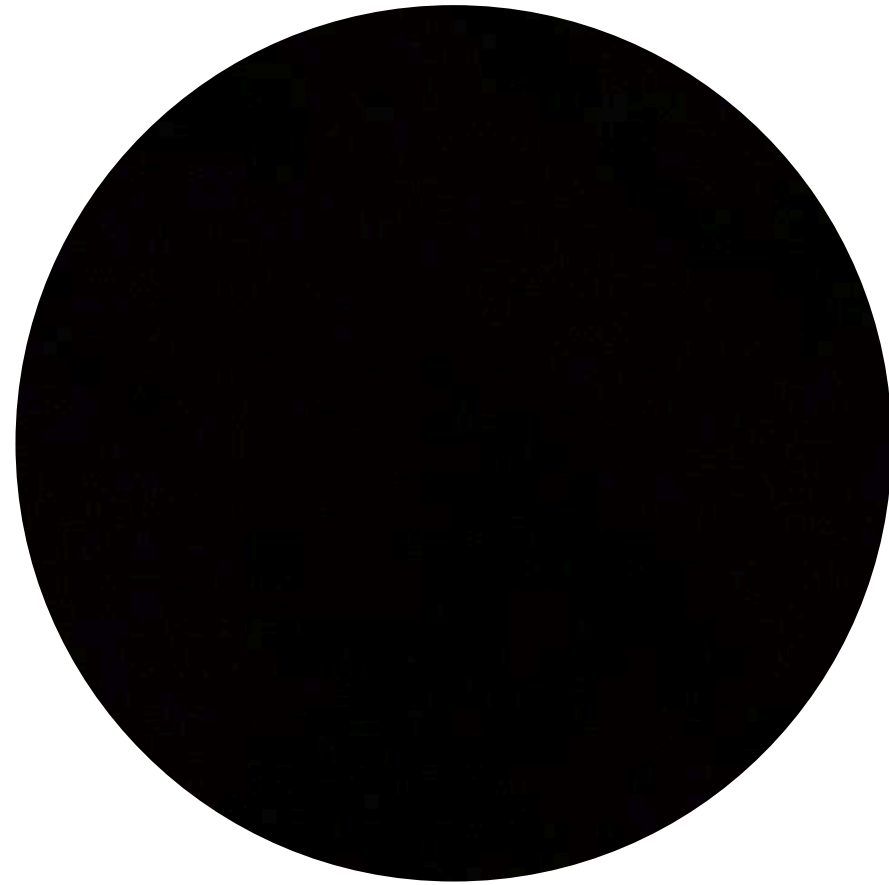

Obsidian (RAL 9011)  
Ferrograin - Indoor

### STANDARD DOME DETAILS

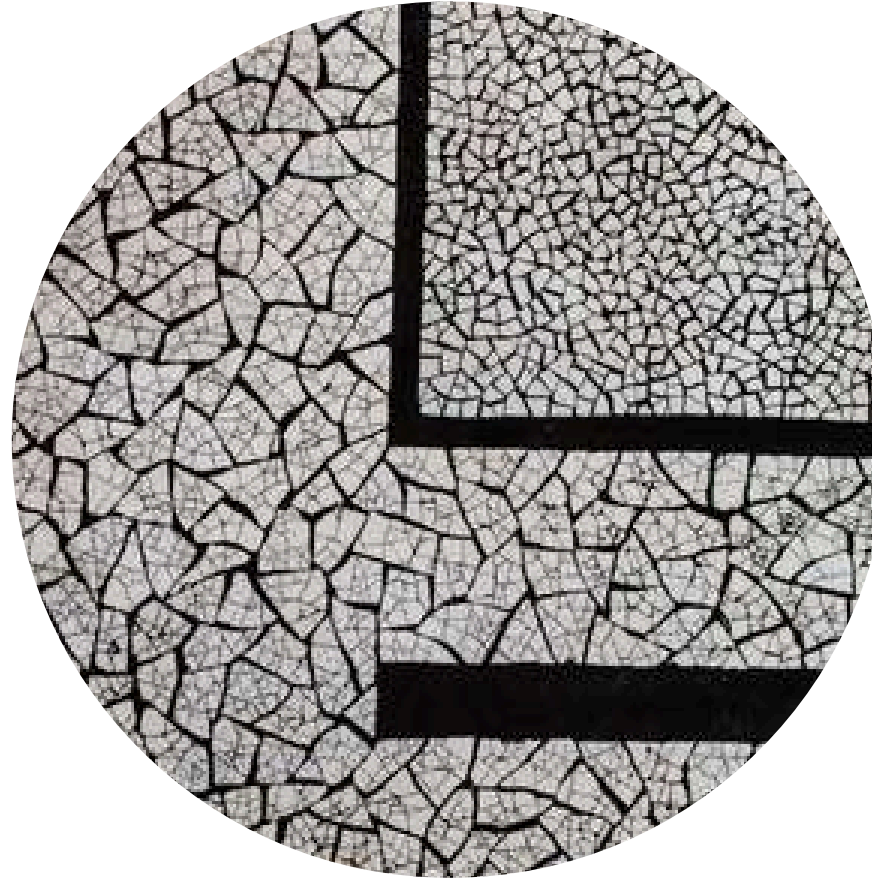

Ostrich Eggshell Mosaic

### STANDARD TRAY DETAILS



Solid White Oak

Cleaning Instructions available on request.

Please Note: Colours may appear different on screen, please request a sample.



# AYA VESSEL I

ENDURANCE  
2026



THEURBANATIVE  
NOT JUST FURNITURE

---

## AYA VESSEL I: ENDURANCE

**Year of Design:** 2020

**Year of Creation:** 2026

### **Description:**

This contemporary vessel presents a sculptural yet restrained form, combining a powder-coated mild steel body with layered stepped detailing and a solid timber base. The cylindrical silhouette is interrupted by subtle stacked rings that introduce rhythm and grounding, while a brass-plated circular tab detail adds a considered accent, balancing utility with ornament. The contrast between matte metal, warm timber, and brass creates a quiet material dialogue, allowing the piece to read as both functional object and collectible form.

The Aya or “fern” Adinkra symbol embodies endurance and resourcefulness. It signifies the ability to overcome adversities and endure difficulties, reflecting the hardiness of the West African fern plant. Aya, pronounced as “eye-ah,” forms part of the more than 700 Adinkra symbols associated with the Gyaman kingdom in Côte d’Ivoire and Ashanti culture in Ghana. The word “Aya” originates from the Twi language, meaning “fern.”

The stylised, simplified geometry of the vessel draws from the visual language of Adinkra symbols, where clarity of form communicates deeper meaning. At first glance the piece appears minimal and direct, yet closer observation reveals layered transitions, precise proportions, and deliberate detailing that echo the complexity embedded within the symbolic tradition that inspires the collection.

In exploring the messages of resilience and resourcefulness carried by the Aya symbol, the collection embraces a layered material approach. Steel, timber, and brass are combined in a way that highlights their individual character while functioning together as a unified whole. The vessel becomes an expression of endurance through structure, material integrity, and thoughtful making, translating cultural narrative into contemporary form.



## AYA VESSEL I: ENDURANCE

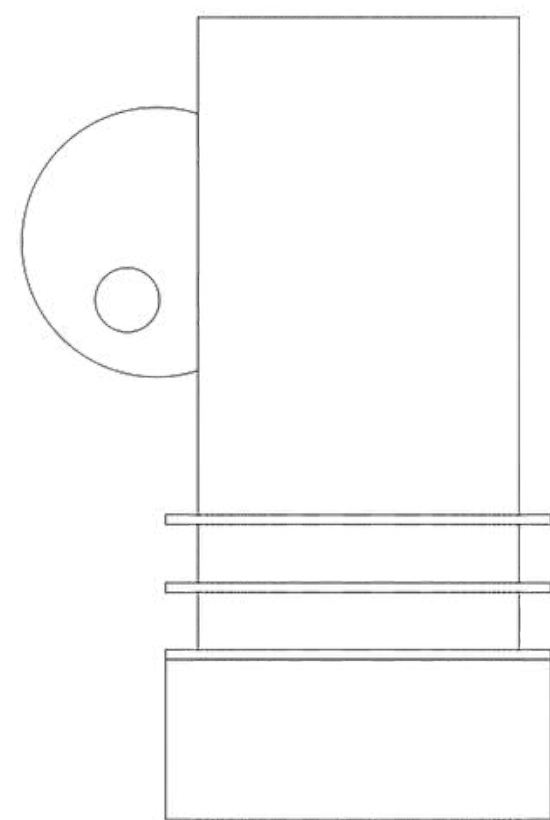
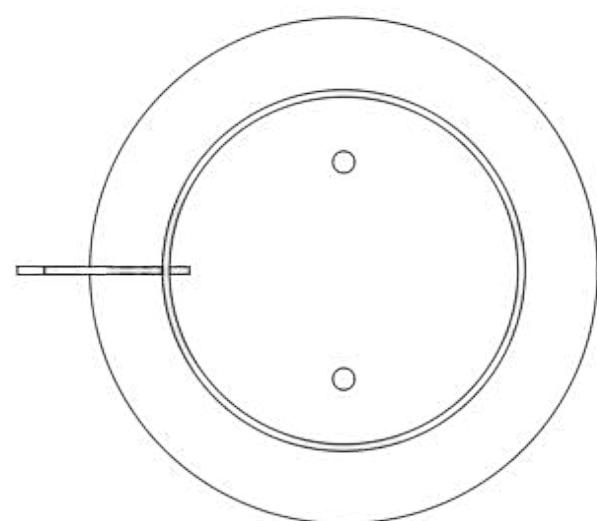

DIMENSIONS 280MM X 120MM X 160MM

---

WEIGHT: 8 KG

---

SKU: AYAVS1-280

---

FINISHES: POWDERCOATED STEEL  
RECLAIMED TIMBER  
BRASS PLATING

---

ENQUIRE FOR PRICING

This contemporary floor lamp boasts a modern design with a powder-coated mild steel frame featuring laser-cut plates. The lampshade showcases a unique mosaic crafted from reclaimed ostrich egg shells in epoxy, supported by a solid oak base and enhanced with brass elements.



**AYA**

*noun*

A-YA

# AYA VESSEL I: ENDURANCE

## MATERIALS SPEC SHEET

### STANDARD POWDERCOATED STEEL COLOURS

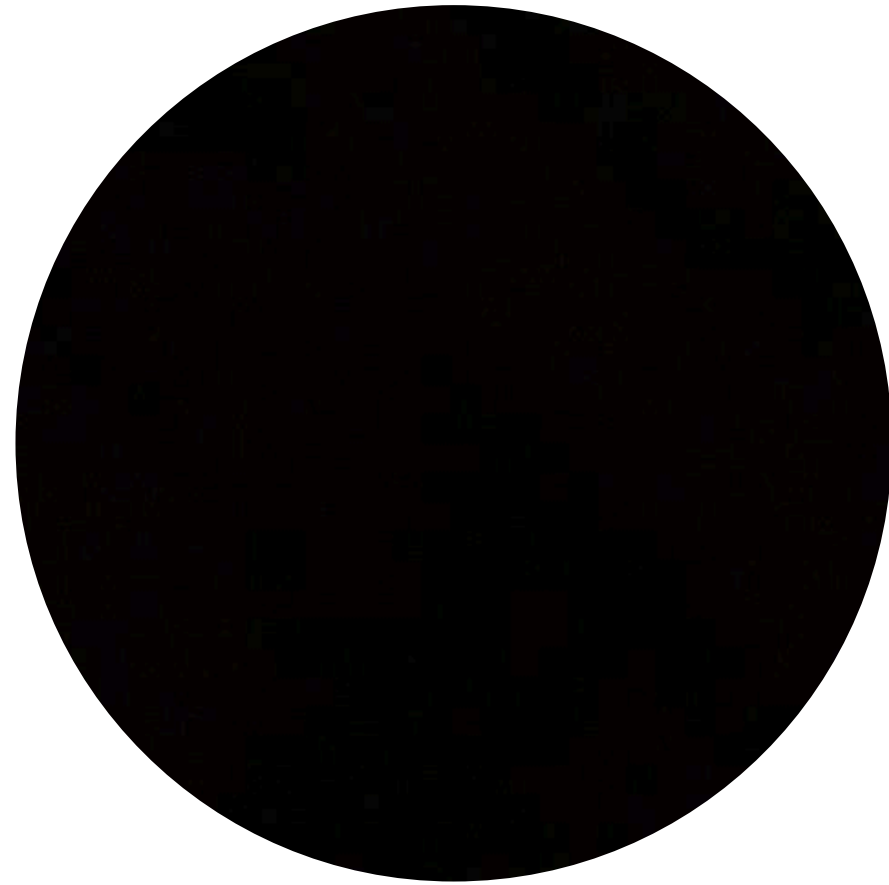

Obsidian (RAL 9011)  
Ferrograin - Indoor

### STANDARD TRAY DETAILS



Solid White Oak

Cleaning Instructions available on request.

Please Note: Colours may appear different on screen, please request a sample.

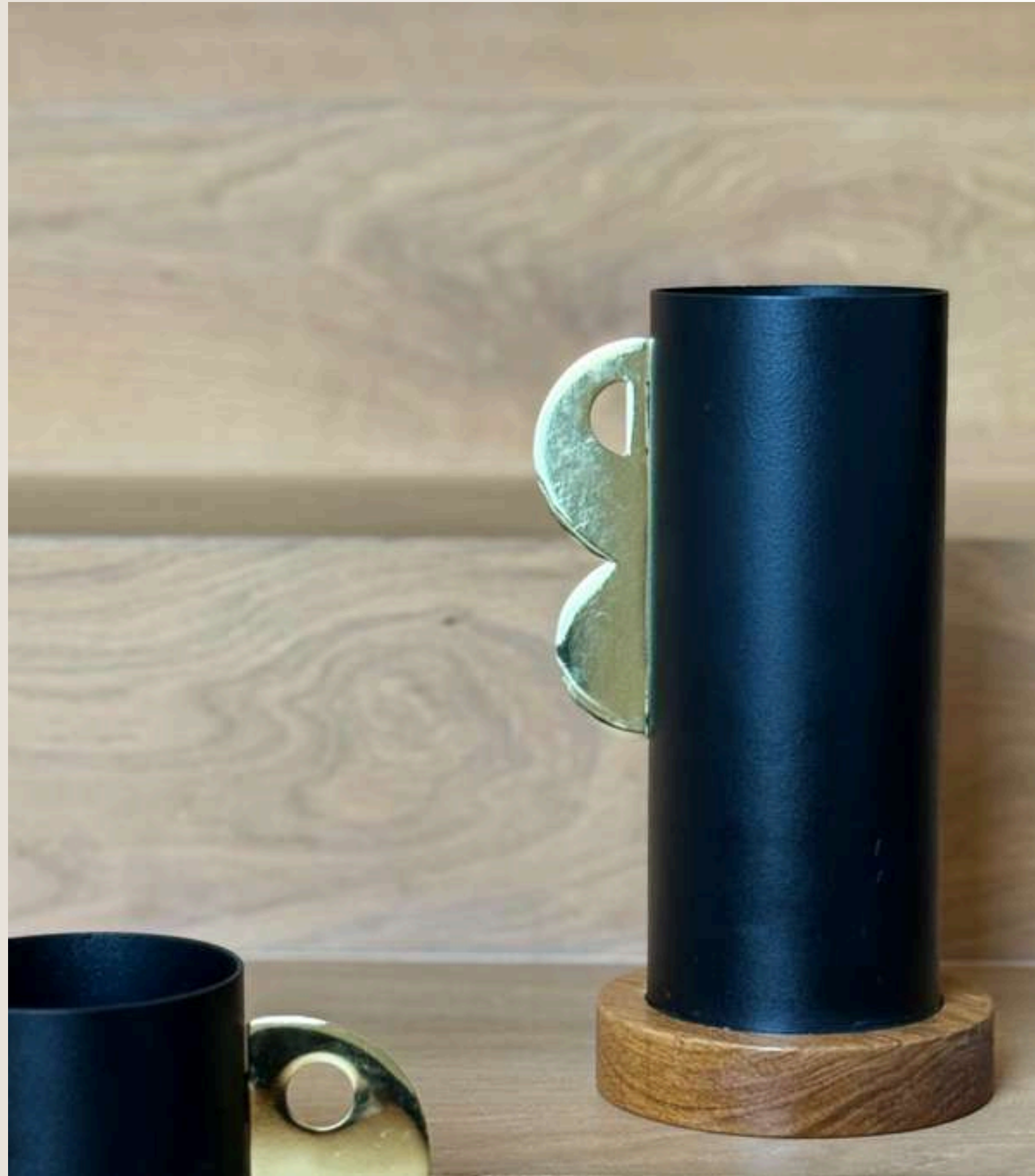

# AYA VESSEL II

REGROWTH  
2026



THEURBANATIVE  
NOT JUST FURNITURE

---



## AYA VESSEL II: REGROWTH

**Year of Design:** 2020

**Year of Creation:** 2026

### **Description:**

This contemporary vessel presents a sculptural yet restrained form, combining a powder-coated mild steel body with layered stepped detailing and a solid timber base. The cylindrical silhouette is interrupted by subtle stacked rings that introduce rhythm and grounding, while a brass-plated circular tab detail adds a considered accent, balancing utility with ornament. The contrast between matte metal, warm timber, and brass creates a quiet material dialogue, allowing the piece to read as both functional object and collectible form.

The Aya or “fern” Adinkra symbol embodies endurance and resourcefulness. It signifies the ability to overcome adversities and endure difficulties, reflecting the hardiness of the West African fern plant. Aya, pronounced as “eye-ah,” forms part of the more than 700 Adinkra symbols associated with the Gyaman kingdom in Côte d’Ivoire and Ashanti culture in Ghana. The word “Aya” originates from the Twi language, meaning “fern.”

The stylised, simplified geometry of the vessel draws from the visual language of Adinkra symbols, where clarity of form communicates deeper meaning. At first glance the piece appears minimal and direct, yet closer observation reveals layered transitions, precise proportions, and deliberate detailing that echo the complexity embedded within the symbolic tradition that inspires the collection.

In exploring the messages of resilience and resourcefulness carried by the Aya symbol, the collection embraces a layered material approach. Steel, timber, and brass are combined in a way that highlights their individual character while functioning together as a unified whole. The vessel becomes an expression of endurance through structure, material integrity, and thoughtful making, translating cultural narrative into contemporary form.

## AYA VESSEL II: REGROWTH

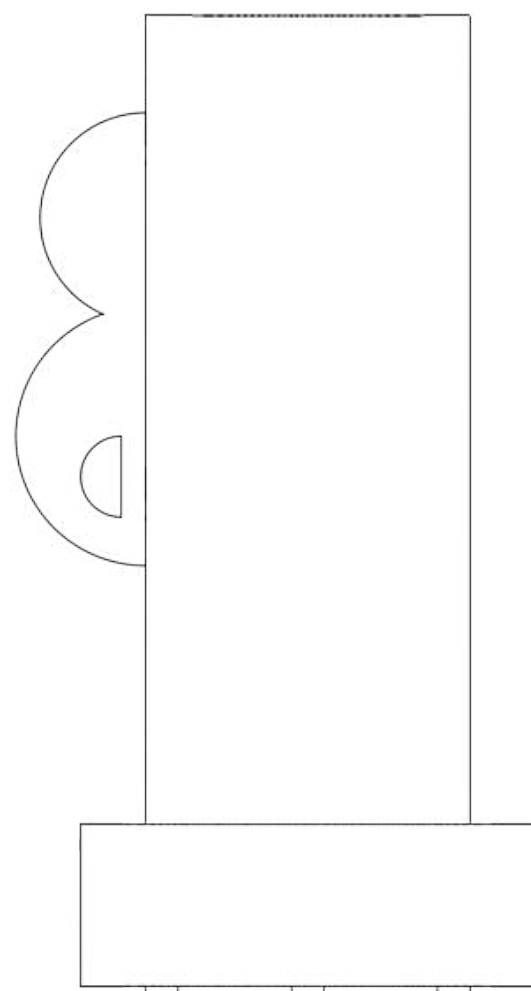
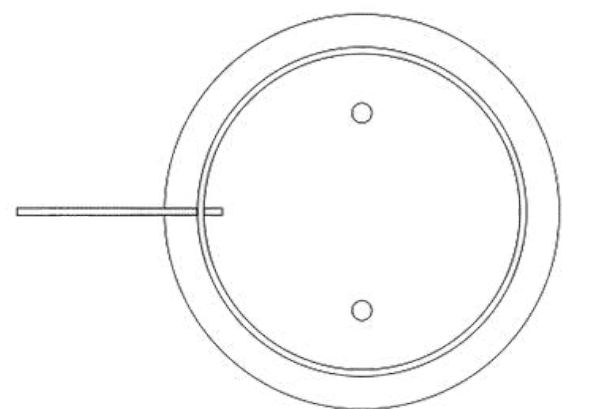

DIMENSIONS 260MM X 120MM X 165MM

---

WEIGHT: 8 KG

---

SKU: AYAVS2-260

---

FINISHES: POWDERCOATED STEEL  
RECLAIMED TIMBER  
BRASS PLATING

---

ENQUIRE FOR PRICING

This contemporary vessel combines a powder-coated mild steel body with stepped detailing, a solid timber base, and a brass-plated accent. Its layered cylindrical form balances sculptural presence with restraint, creating a dialogue between matte metal, warm timber, and brass that positions the piece as both functional and collectible.



**AYA**

*noun*

A-YA

# AYA OBELISK

## MATERIALS SPEC SHEET

### STANDARD POWDERCOATED STEEL COLOURS

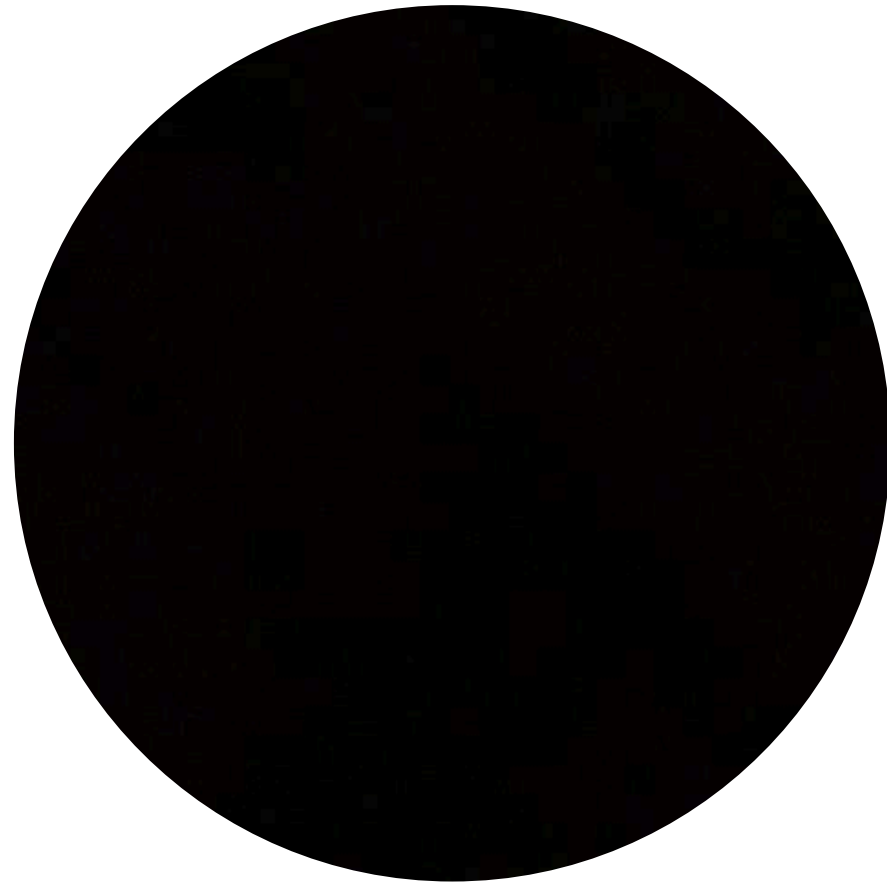

Obsidian (RAL 9011)  
Ferrograin - Indoor

### STANDARD TRAY DETAILS



Solid White Oak

Cleaning Instructions available on request.

Please Note: Colours may appear different on screen, please request a sample.



# AYA TRAY I

GROUNDING  
2026



THEURBANATIVE  
NOT JUST FURNITURE

---

## AYA TRAY I: GROUNDING

**Year of Design:** 2020

**Year of Creation:** 2026

### **Description:**

This contemporary tray explores sculptural form through the interplay of reclaimed timber and a powder-coated mild steel frame. The circular composition reveals a carefully balanced arrangement of contrasting wood tones, shaped into flowing geometric segments that suggest movement and continuity. Each timber component is selected from reclaimed material, allowing the natural grain, colour variation, and history of the wood to become an integral part of the design. As a result, no two pieces are alike, with every vessel carrying its own unique character and story.

The stylised geometry of this piece draws from the visual language of Adinkra symbols, where simplified forms carry layered meanings. At first glance the composition appears calm and resolved, yet closer observation reveals a complexity of joinery, grain direction, and proportion that reflects the depth of the cultural references informing the collection.

In exploring the themes of endurance and resourcefulness embodied by the Aya symbol, the vessel embraces a layered material approach. Reclaimed timber is given renewed purpose within a precise steel framework, celebrating both sustainability and craftsmanship. The piece becomes an expression of transformation, where material history and contemporary design converge to create an object that is both functional and collectible.



## AYA TRAY I: GROUNDING

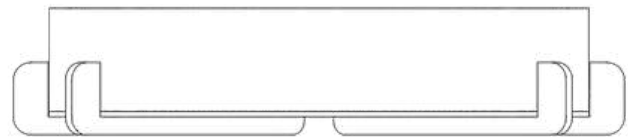
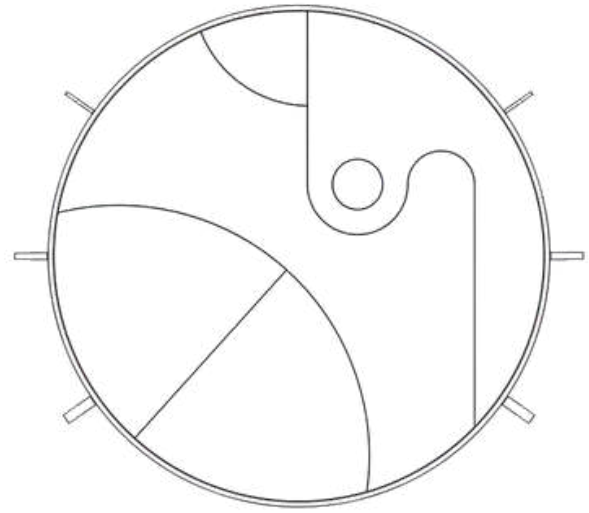

DIMENSIONS 340MM X 300MM X 70MM

WEIGHT: 10 KG

SKU: AYATR01-340

FINISHES: POWDERCOATED STEEL  
RECLAIMED TIMBER

ENQUIRE FOR PRICING

This contemporary vessel combines a powder-coated mild steel body with stepped detailing, a solid timber base, and a brass-plated accent. Its layered cylindrical form balances sculptural presence with restraint, creating a dialogue between matte metal, warm timber, and brass that positions the piece as both functional and collectible.

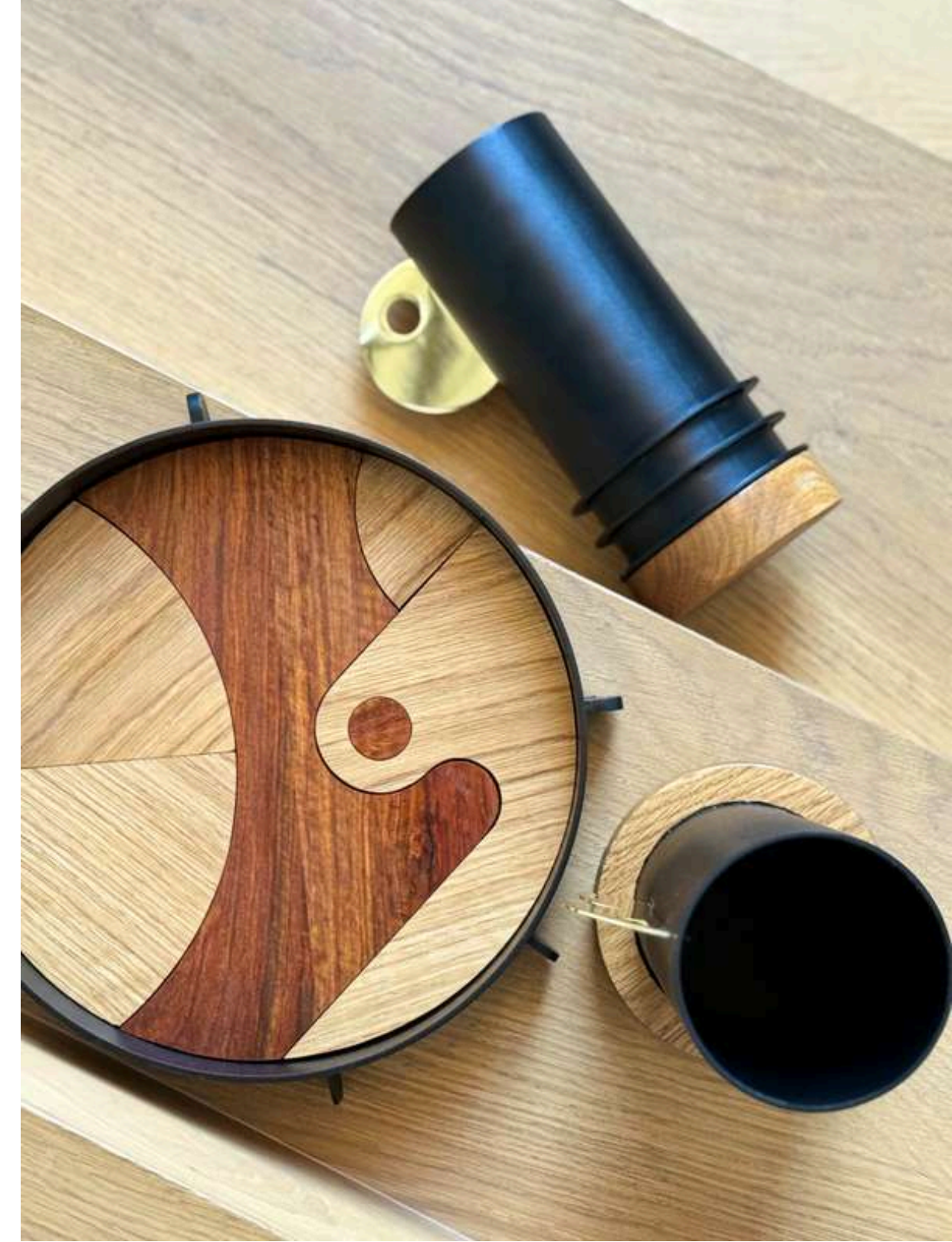

**AYA**

*noun*

A-YA

# AYA TRAY I: GROUNDING

## MATERIALS SPEC SHEET

### STANDARD POWDERCOATED STEEL COLOURS

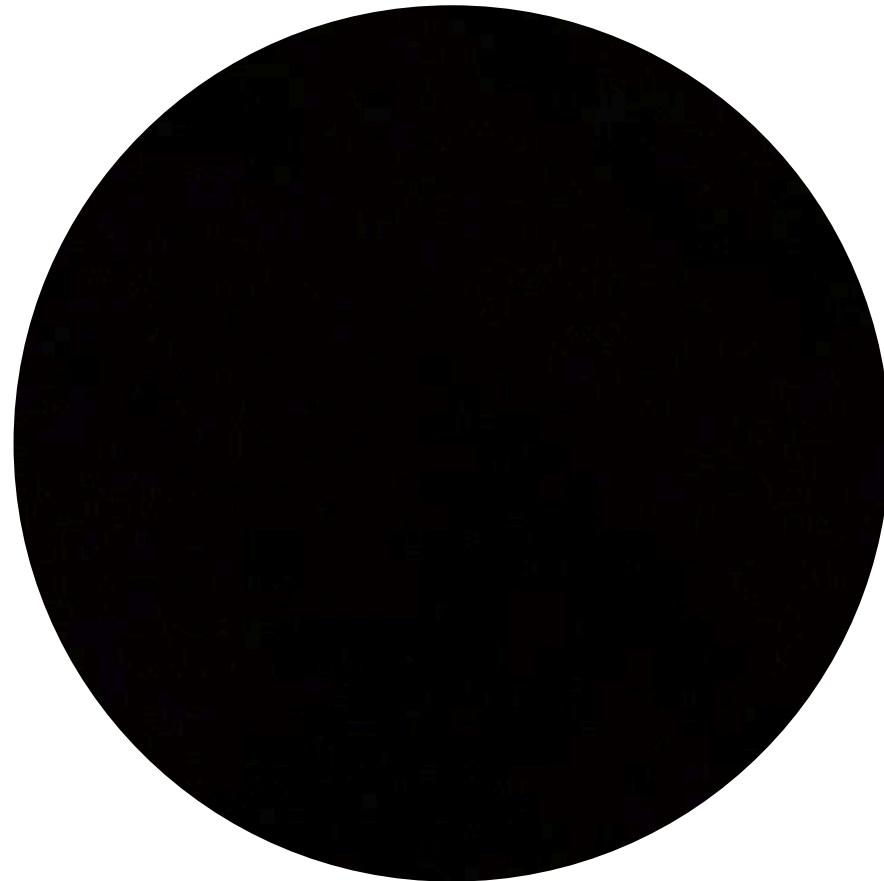

Obsidian (RAL 9011)  
Ferrograin - Indoor

Cleaning Instructions available on request.

Please Note: Colours may appear different on screen, please request a sample.

### STANDARD TRAY DETAILS



Solid White Oak



Solid Kiaat



Solid White Oak



Solid European Ash